

HERZ pellet boiler with condensing technology

Efficiency rate
 η up to 106%



pelletstar
CONDENSATION 10-60



pelletstar
CONDENSATION 80-101



Competence is our success ...

HERZ FACTS:

- 50 subsidiaries
- Group headquarter in Austria
- Research & development in Austria
- Austrian owner
- 3.000 employees in over 100 countries
- 40 production sites



HERZ Armaturen GmbH – The company

Founded in 1896, HERZ has a continuous, more than 125-year-old market presence. With 6 sites within Austria, another 24 in Europe and more than 3.000 employees at home and abroad, HERZ is the only Austrian manufacturer that produces equipment for the entire heating and installation industry and is one of the most important internationally.



HERZ Energietechnik GmbH

HERZ Energietechnik employs 200 people in production and sales. At the company sites in Pinkafeld/Burgenland and Sebersdorf/Styria, there is state-of-the-art production as well as a research institute for new, innovative products. Proven cooperations with research and educational institutions can be intensified. Over the years, HERZ has established itself as a specialist in renewable energy systems. HERZ places a great importance on modern, cost-effective and environment friendly heating systems with the highest level of convenience and user-friendliness.

HERZ for the environment

All HERZ biomass systems fall below the strictest emission regulations. Numerous environmental endorsements bear witness to this.

HERZ quality

Our HERZ design engineers are in permanent contact with acknowledged research institutions in order to improve the very high standards continuously.



Comfortable heating with latest technology from HERZ

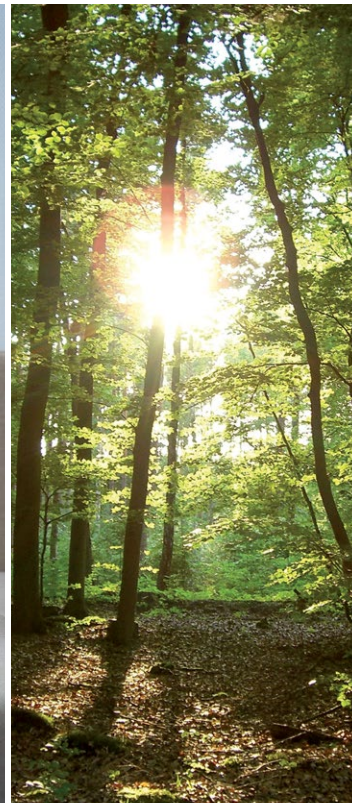

pelletstar CONDENSATION

Pellet boiler with condensing technology



Up to 106% efficiency rate

The steam which is contained in the flue gas is cooled down so far that liquid condensate is formed in the heat exchanger.

With this cooling process (liquefaction) condensing heat is released and can be used for heating purposes. Due to the condensing technology efficiencies up to 106% can be achieved.



Wood pellets (Ø 6mm) according to

- EN ISO 17225-2: Property class A1
- ENplus, DINplus or Swisspellet

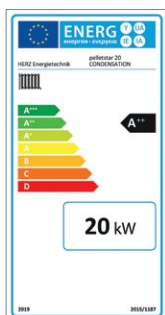

Energy efficiency class

Biomass boiler **A+++**

Biomass boiler with integrated system controller **A+++**

The big advantages:

- **For underfloor heating & radiators**
The HERZ pelletstar CONDENSATION is the ideal solution for new buildings as well as for renovations. The heat distribution can be done via a low temperature system (underfloor heating) or a high temperature system (radiators). Depending on requirement the pelletstar CONDENSATION delivers the correct temperature also without buffer tank.
- **Modular design**
Due to the modular design, the insertion and assembly can be carried out very quickly and easily. In addition, the system can be placed on two sides (back & side) in flush with the wall and provides therefore, also for existing boiler rooms with limited space, an optimal solution.
- **Complete boiler body is 100% made of stainless steel**

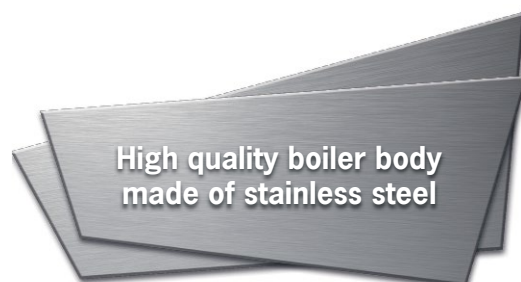

High quality boiler body
made of stainless steel

Easy, modern and comfortable ...



With the user-friendly touch-control-unit „T-Control“, heating circuits, boilers, buffers and solar can be controlled in addition to the combustion process.

T-CONTROL

The central control unit for:

- Combustion control
- Lambda probe control (controls the combustion air and fuel input)
- Buffer management module
- Control for domestic hot water preparation (via hot water tank or buffer with fresh water modul)
- Flow temperature booster during domestic hot water preparation (pump and mixer Valve)
- Controlled heating circuits (pump and mixer valve)
- Solar circuit control
- Frost protection monitoring



The convenient menu and simple screen layout with schematic 3D-representation ensures maximum user-friendliness.

The “modular operation” of the T-Control offers extension possibilities up to 30 modules. This allows the central control unit to process the combustion (with lambda sensor), buffer management, return temperature rise, heating circuits, hot water preparation, solar circuit and more optimal together. Additionally, the control system can be easily expanded or modified with the external modules.

Further advantages of the T-Control:

- Power-saving standby mode
- Status and error messages via e-mail
- Data transfer and software updates via USB stick
- Possibility of Modbus-communication
- Easy and clear presentation of the functions from various components (heating circuit pump, hot water tank loading pump, circulation pump, mixing valve, switching valve, actuator motors etc.)

... with the central control unit T-CONTROL



Remote access to the control via the myHERZ-portal very easy from everywhere

As an additional option, the T-Control offers the possibility for remote visualisation and remote maintenance via smartphone, PC or tablet PC. The handling is the same as in the Touch-Control directly on the boiler. The processes and parameters can be read and modified any time from anywhere.

Remote access via myherz.at

Cascade operation

Using the HERZ T-Control, up to 8 HERZ boilers equipped with T-CONTROL can be switched to cascade (CAN BUS). A special advantage of the cascade arrangement is the efficient utilization of the boiler at lower heat consumption (eg in the transitional period).



Benefits and details ...



T-Control - the user-friendly control with touch display

- **Central control unit as standard for:**
 - Combustion control
 - Buffer management module
 - Control for domestic hot water preparation (via hot water tank or buffer with fresh water modul)
 - Flow temperature booster during domestic hot water preparation (pump and mixer Valve)
 - Lambda probe control (controls the combustion air and fuel input)
 - Frost protection monitoring
- **Simple screen design and convenient menu guide.**
- **Extension possibilities up to 30 modules:**
 - Controlled heating circuits (pump and mixer valve)
 - Solar circuit control
 - Further buffer management



High heat resistant stainless steel Burning chamber

- Made of high heat-resistant steel - for longest lifetime

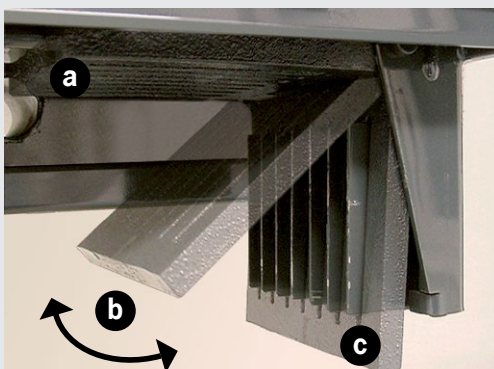

Automatic cleaning of the combustion grate by double tipping grate

- The combustion grate is automatically cleaned by tipping the grate against a matrix.
- Due to the clean combustion grate an optimal air supply is guaranteed.
- The ash that accumulates in the combustion chamber is transported to the ash box below. The ash box is easily accessible from the front and can be emptied.

- a) Combustion tipping grate closed (during heating mode)
- b) Combustion tipping grate tilts down by motor drive
- c) Combustion tipping grate presses against a matrix

Illustration: suction discharge system



Figure: auger discharge system

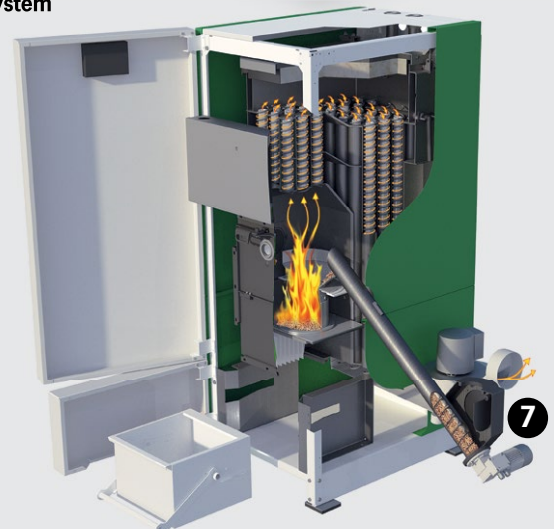

...of the HERZ pelletstar CONDENSATION 10-60

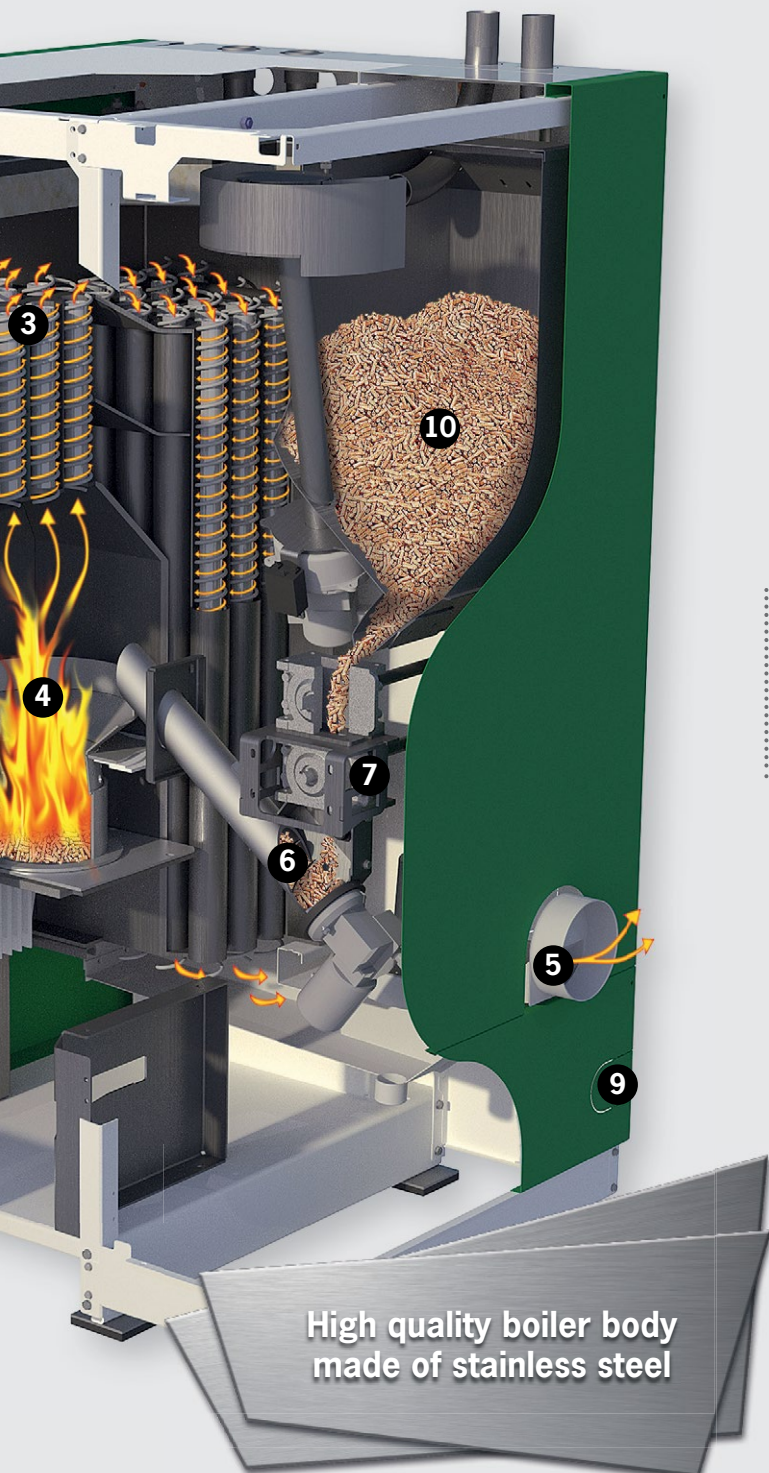

**High quality boiler body
made of stainless steel**

**Complete boiler body is 100%
made of stainless steel**

Energy saving combustion due to the lambda probe



- A built in lambda probe, which monitors continuously the flue gas content values, detects fuel quality changes and ensures optimum combustion and low emission values.
- The Lambda probe controls the air supply and ensures the cleanest combustion, even in part load operation.
- The results are lower fuel consumption and lowest emission values even with different fuel qualities.

Automatic cleaning of the heat exchanger



- The heat exchanger surfaces made of stainless steel are cleaned automatically via a flushing mechanism as well as via the integrated turbulators, even during heating operation and therefore no manual cleaning is necessary.
- A consistently high level of efficiency by purified heat exchanger surfaces means lower fuel consumption.

Double rotary valve unit 45-60 kW

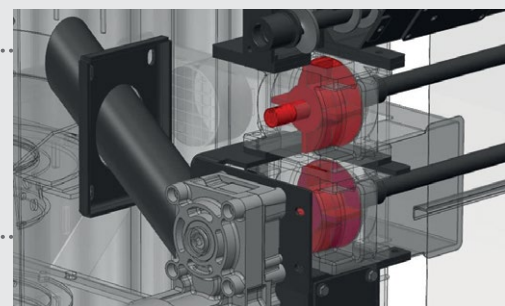

- The double rotary valve for 45-60 kW enables heating operation during the suction operation.
- Single cell wheel for 10-30 kW

- 1. Combustion tipping grate with a matrix**
- 2. Lambda probe control**
Automatic flue gas and combustion monitoring
- 3. Automatic cleaning of the heat exchanger through**
 - integrated turbulators
 - flushing mechanism (water)
- 4. Combustion chamber with tipping grate**

- 5. ID-fan**
- 6. Pellets insertion**
- 7. Certified back fire protection flap (BFP):**
 - rotary valve (at integrated hopper or suction hopper)
 - autonomous tight closing flap (at screw discharge systems or extern hopper)
- 8. Integrated ash box for the combustion ash**

- 9. Condensate- and cleaning water drain:**
- 10. Integrated suction hopper**
 - for suction discharge system:
10-30 kW: 56 litres
45-60 kW: 87 litres
 - or hand filling hopper**
 - for manual filling:
10-30 kW: 106 litres
45-60 kW: 150 litres

Benefits and details ...



T-Control - the user-friendly control with touch display

- **Central control unit as standard for:**
 - Combustion control
 - Buffer management module
 - Control for domestic hot water preparation (via hot water tank or buffer with fresh water modul)
 - Flow temperature booster during domestic hot water preparation (pump and mixer Valve)
 - Lambda probe control (controls the combustion air and fuel input)
 - Frost protection monitoring
- **Simple screen design and convenient menu guide.**
- **Extension possibilities up to 30 modules:**
 - Controlled heating circuits (pump and mixer valve)
 - Solar circuit controll
 - Further buffer management

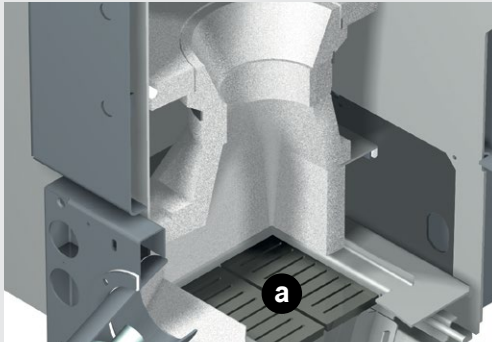

Combustion chamber with high temperature resistant lining

- Made of high temperature resistant refractory concrete (SiC) – for longest lifetime

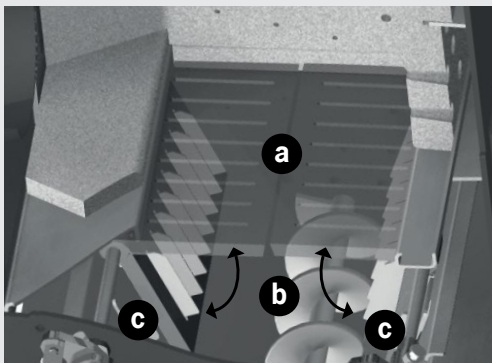

Automatic cleaning of the combustion grate by double tipping grate

- The combustion grate is automatically cleaned by tipping the double grates against matrices.
- Due to the clean combustion grate an optimal air supply is guaranteed.
- The ash that accumulates in the combustion chamber is thrown into the ash screw below and automatically transported to the external ash box on the front.

- a) Combustion tipping grate closed (during heating mode)
- b) Each combustion tipping grate tilts down by motor drive
- c) Combustion tipping grate presses against each matrix

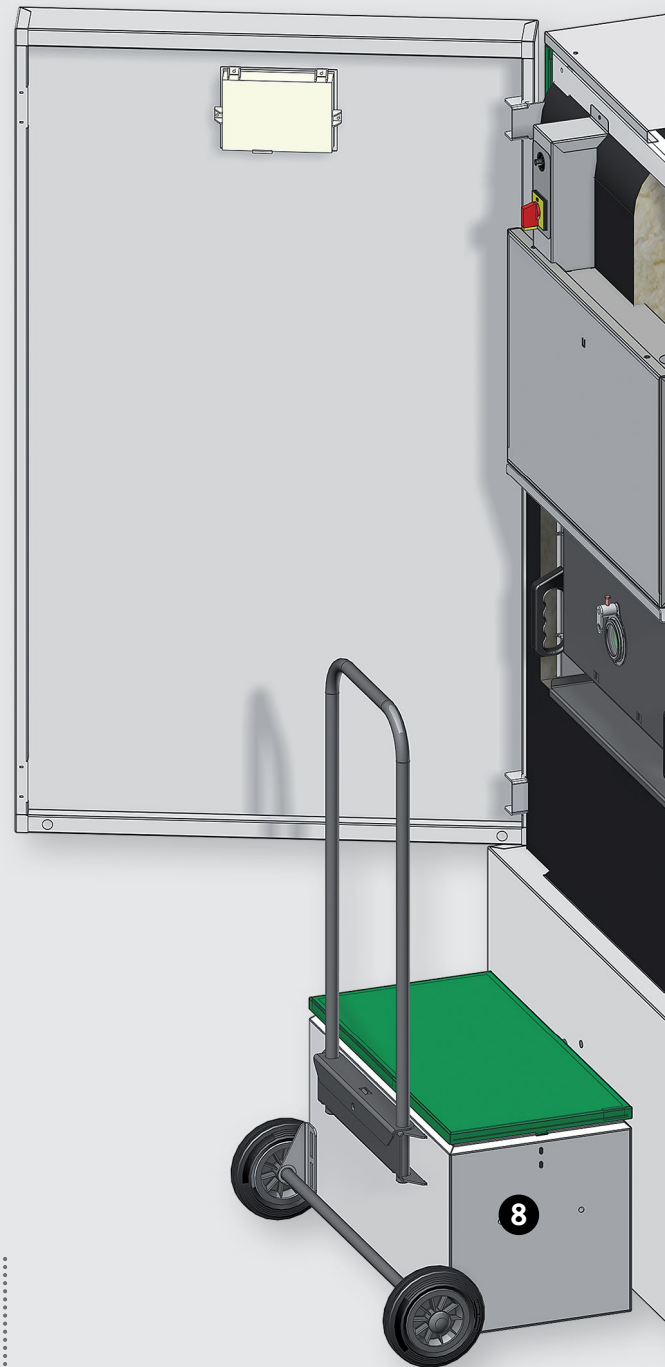

High quality boiler body made of stainless steel

Complete boiler body is 100% made of stainless steel

...of the HERZ pelletstar CONDENSATION 80-101

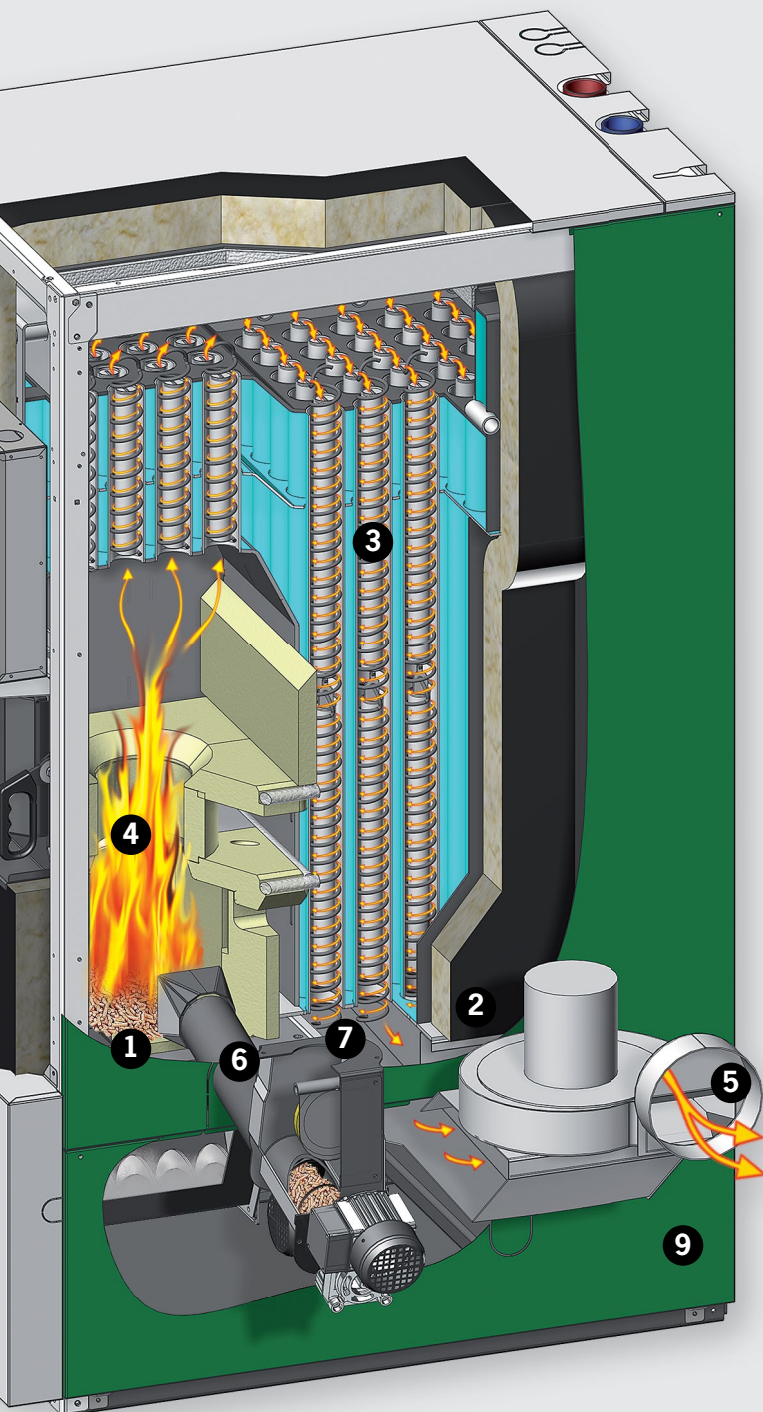

Energy saving combustion due to the lambda probe



- A built in lambda probe, which monitors continuously the flue gas content values, detects fuel quality changes and ensures optimum combustion and low emission values.
- The lambda probe controls the air supply and ensures the cleanest combustion, even in part load operation.
- The results are lower fuel consumption and lowest emission values even with different fuel qualities.

Automatic cleaning of the heat exchanger



- The heat exchanger surfaces made of stainless steel are cleaned automatically via a flushing mechanism as well as via the integrated turbulators, even during heating operation and therefore no manual cleaning is necessary.
- A consistently high level of efficiency by purified heat exchanger surfaces means lower fuel consumption.

1. **Double tipping grate with matrix**
2. **Lambda probe control**
Automatic flue gas and combustion monitoring
3. **Automatic cleaning of the heat exchanger through**
 - integrated turbulators
 - flushing mechanism (water)
4. **Combustion chamber with double tipping grate**

5. **ID-fan**
6. **Pellets insertion**
7. **Certified back fire protection flap (BFP):**
 - automatically tight closing flap
8. **External ash box for the combustion ash**

9. **Condensate- and cleaning water drain**

Full automatic pellets discharge systems

HERZ offers a variety of solutions to store the wood pellets and to discharge the fuel via various systems to the boiler. Whether a room discharge with flexible screw or suction system: Due to the wide range of discharge variants, HERZ has the optimal solution for each room and space situation.

If there is no pellet storage room available, there is also the possibility of a bag silo, which can be placed for example, directly in the boiler room.

Discharge via flexible screw

The room discharge with a flexible screw is an easy and energy saving solution to empty the storage room in an efficient way.

The advantages of the flexible screw discharge system

- Inexpensive purchase
- Extremely quiet operation
- Gentle transport of the pellets
- Flexible screw bending radius: min. 1.25 metres
- Length of the screw: max. 9.5 metres)
(for longer distances a solution with a transfer system to a second flexible screw is possible)
- Max. dumping height: 3 metres

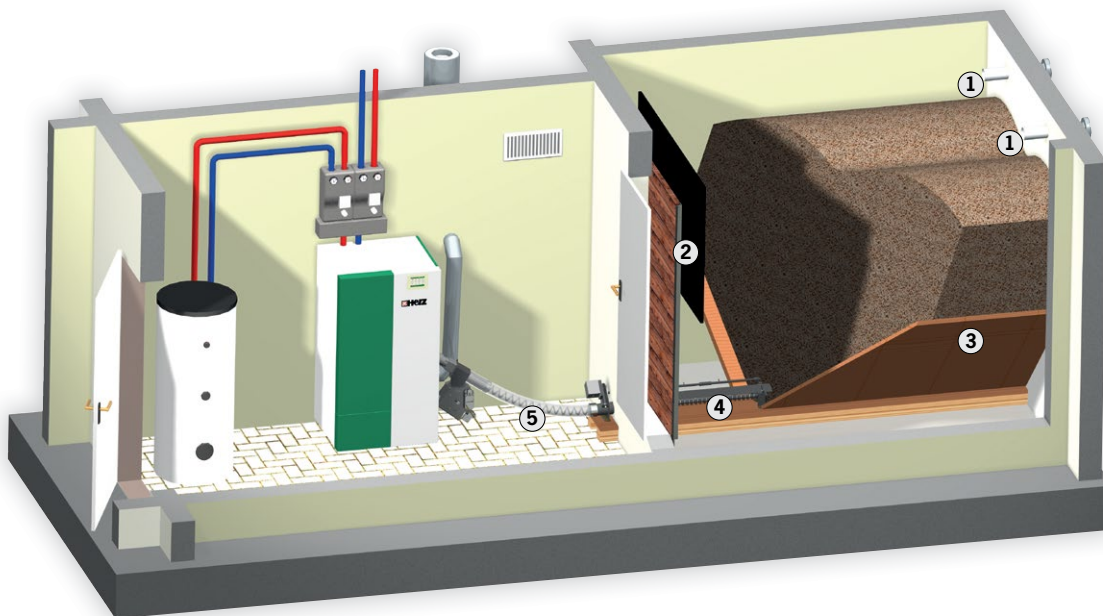
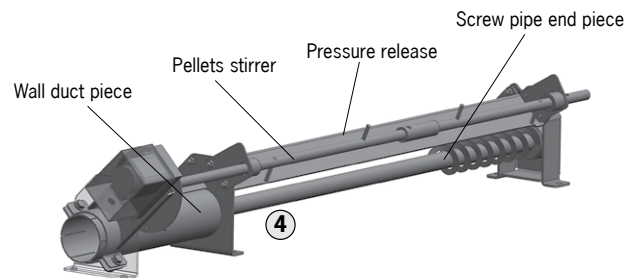

1. Injection and extraction nozzles

The pellets are blown into the storage room via an injection and suction nozzle. At least one injection nozzle and one suction nozzle are required, since dust and the necessary conveying air are extracted in a controlled manner in parallel to the blowing-in process.

2. Impact mat

An impact mat serves to protect the pellets during the blow in and is mounted opposite of the injection and extraction nozzles.

3. Slide ramps

In order to empty the storage room completely a sloping floor is recommended.

4. Screw system in the storage room

5. Flexible screw

The flexible discharge screw consists of a screw spiral which gently transports the pellets to the boiler.

Discharge via flexible screw - chute pipe system

The storage room is located one floor higher than the boiler room or in the attic? This is no problem with the flexible screw discharge with chute pipe system!

Chute pipe

The pellets are transported via the chute pipe directly to the boiler.

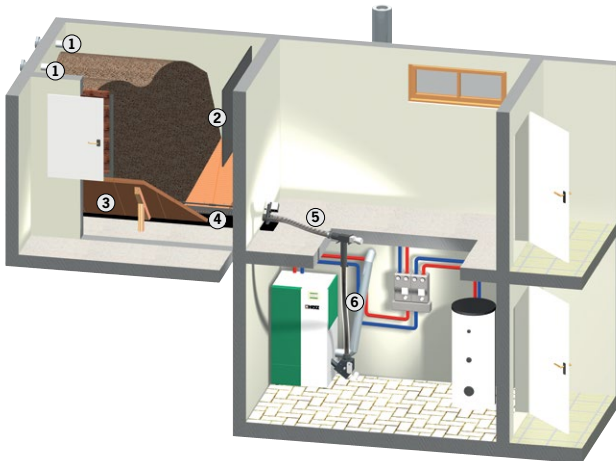

Chute pipe system and adapter

After the chute pipe the pellets are transported via a transfer station with an additional flexible screw to the boiler. This results in even more flexibility and the system can be optimally adapted to the local conditions.

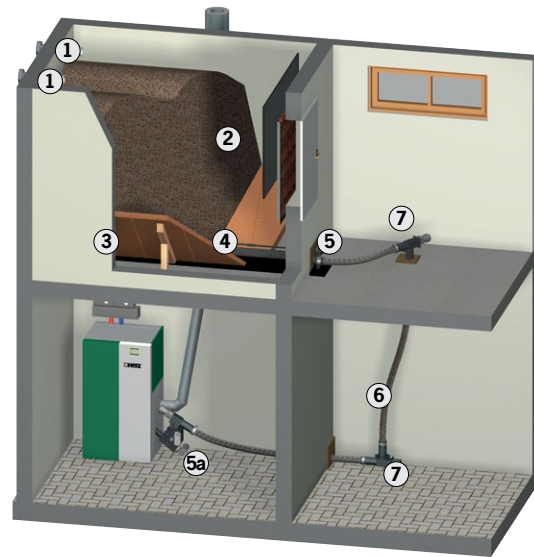

1. Injection and extraction nozzles
2. Impact mat
3. Slide ramps
4. Screw system in the storage room
5. Flexible screw
- 5a. Second flexible screw
6. Chute pipe
7. Transfer system

Discharge via flexible screw - transfer system

Transfer system FIXED:

The transfer unit is located immediately after the storage room.

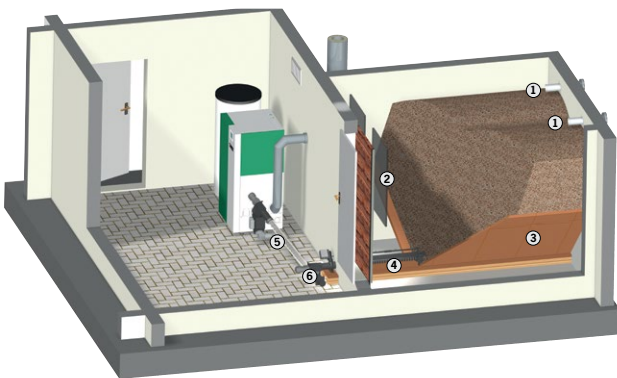

Transfer system:

The pellets are transported after the storage room via two flexible screws with intermediate transfer unit to the boiler. This makes it even more flexible and can also be used for larger distances.

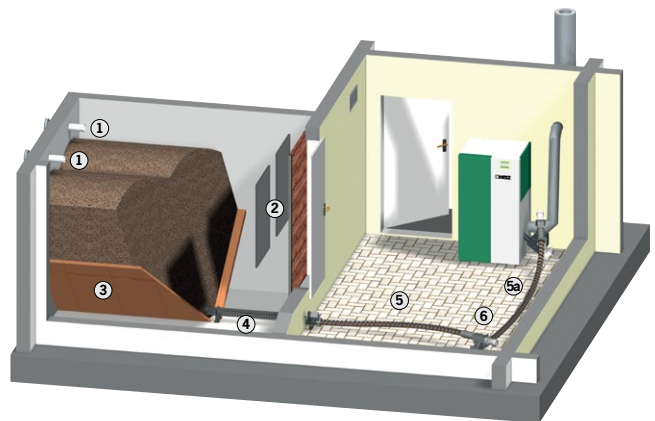

1. Injection and extraction nozzles
2. Impact mat
3. Slide ramps
4. Screw system in the storage room
5. Flexible screw
- 5a. Second flexible screw
6. Transfer system

Full automatic pellets discharge systems

Discharge via suction system

The suction systems of HERZ are the ideal solution for longer distances from the storage room to the boiler.

Modular discharge screw in the storage room in combination with suction system:

Optimum emptying of the storage room and individual positioning of the boiler.

The advantages of the suction discharge system

- Clean and dust-free pellets transport also for long distances from storage room to the boiler room.
- Flexible, individual installation and guidance of the suction and reverse air tube (depending on local conditions).

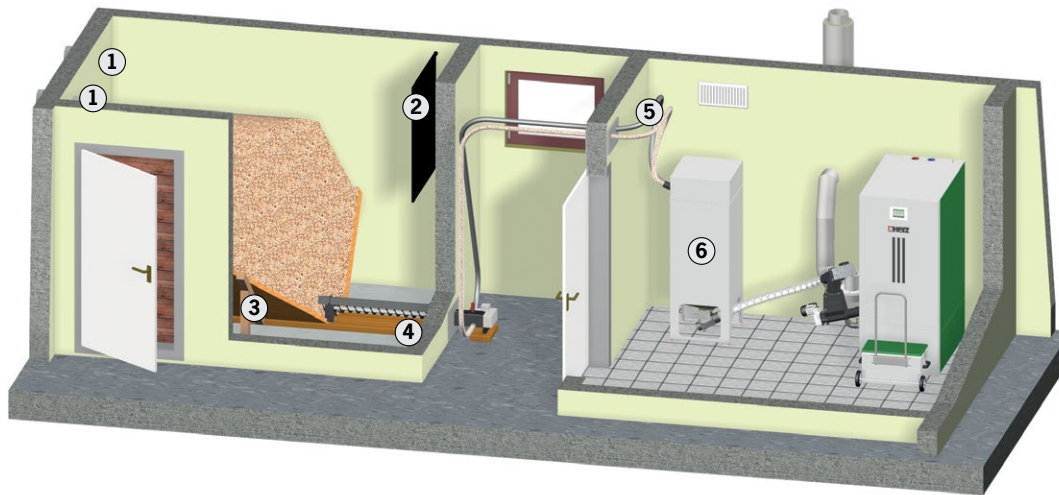

1. Injection and extraction nozzles

The pellets are blown into the storage room via an injection and suction nozzle. At least one injection nozzle and one extraction nozzle are required, since dust and the necessary conveying air are extracted in a controlled manner in parallel to the blowing-in process.

2. Impact mat

An impact mat serves to protect the pellets during the blow in and is mounted opposite of the injection and extraction nozzles.

3. Slide ramps

In order to empty the storage room completely a sloping floor is recommended.

4. Auger discharge system

The transport of pellets from the storage room is done via a screw discharge.

5. Suction- and reverse air tube

The suction- and reverse air tubes can be installed flexible and individually adapted to the local conditions. Thereby long distances between the storage room and the heating room can be realized.

6. Pellet hopper inclusive suction turbine

In the suction discharge variant of the boiler, a suction hopper (including suction turbine) can be set up.

Modular discharge screw in the storage room in combination with suction system:

The screw system in the storage room is modular, that means the system consists of elements which can be combined according to the room situation or the room size.

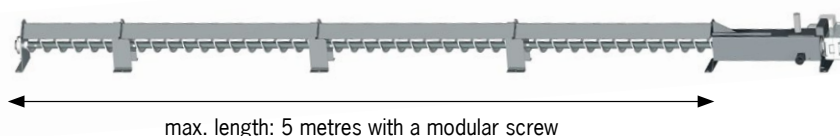

Discharge via point suction system

4-point suction system

The position of the 4 suction points is individually selectable. The system can be installed easily and is an adaptable, universal solution to each storage room situation.

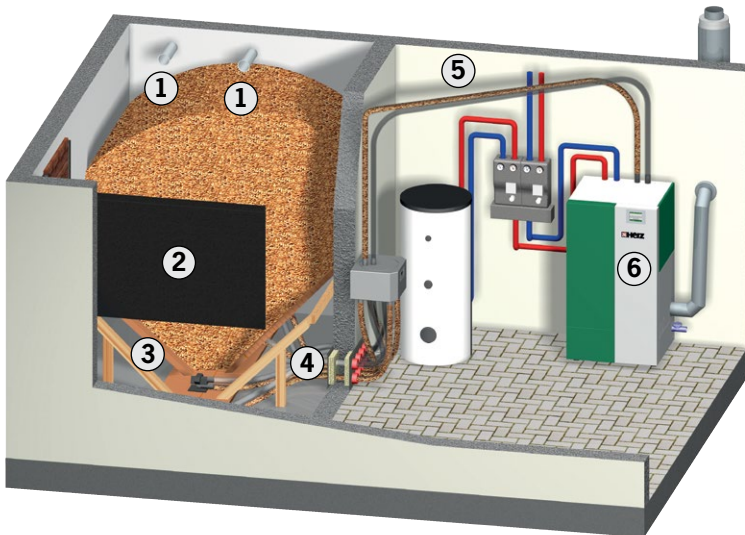

1. Injection and extraction nozzles
2. pellets impact mat
3. Slide ramps
4. Suction probe
5. Suction- and reverse air tube
6. Integrated pellet hopper inclusive suction turbine for 10-60 kW
 - for 80 - 101 kW is an external hopper necessary

8-point suction system

The position of the eight suction points is individually selectable. The system can be installed easily and is an adaptable, universal solution to each storage room situation.

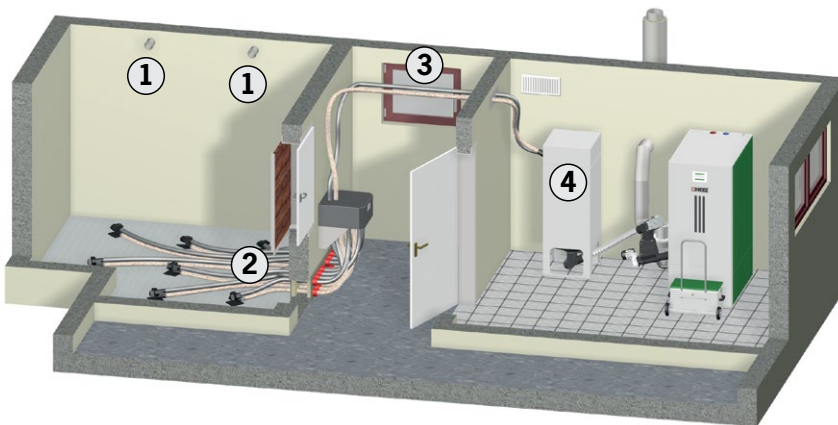

1. Injection and extraction nozzles
2. Suction probe
3. Suction- and reverse air tube
4. External pellet suction hopper with flexible screw is required for 80-101 kW
 - for 10-60 kW the suction hopper is integrated in the boiler

Discharge system with 1 suction probe: Ideal for small storage rooms and less pellets demand (1-point suction).

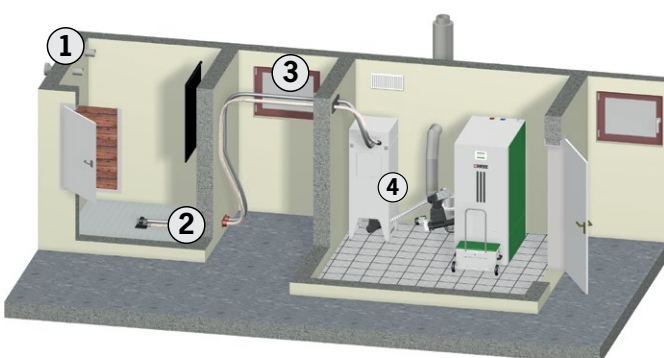

1. Injection and extraction nozzles
2. Suction probe
3. Suction- and reverse air tube
4. External pellet suction hopper with flexible screw is required for 80-101 kW
 - for 10-60 kW the suction hopper is integrated in the boiler

Storage systems from HERZ

System bag silo



THE ADVANTAGES IN DETAIL:

Simple and quick installation

The bag silo can be installed & assembled easily and fast. If the silo is not on the right place after installation, it can be easily rearranged.

Clean

The special antistatic polyester fabric prevents that dust escapes from the silo, whereby a clean filling and a dust-free operation is possible.

Careful storage

The pellets are protected during filling by the integrated impact mat inside of the bag silo. In addition, the silo provides an optimal environment for the careful storage of the fuel.

Individual placeable

The place of installation of the silo can be selected individually. Due to the variety of the pellets discharge systems HERZ offers for each place and room situation the optimum solution.

User friendly

The complete system saves time-consuming constructions and installation costs. Additionally, the system offers the cost-effective acquisition and full automatic & maintenance-friendly operation.

The HERZ bag silo is available in different sizes with storage capacities from 1.1 up to 11.7 m³. If no pellet storage room is available, there is the possibility of a bag silo. The bag silo can be placed directly in the boiler room (depending on national regulations).

Room discharge with flexible screw from a bag silo

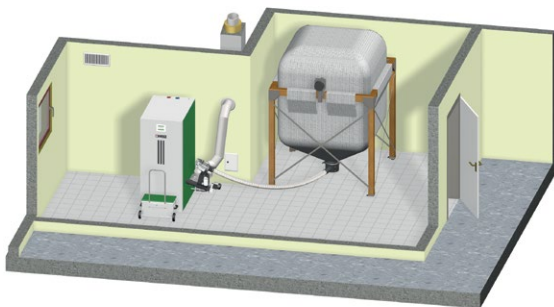

Suction discharge via suction system from a bag silo

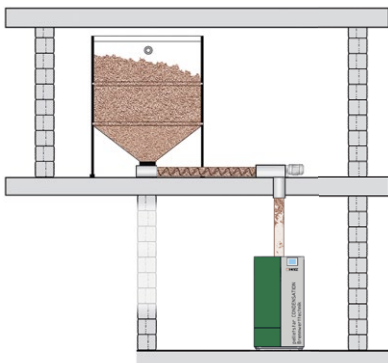
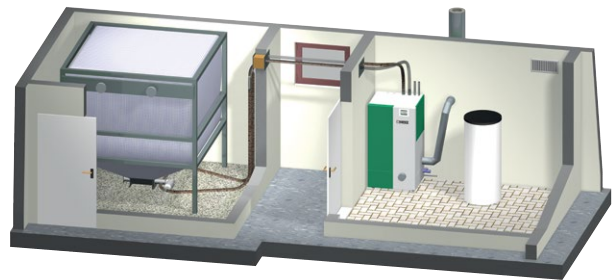

If the bag silo is placed a floor higher the pellets transport is done via a flexible discharge screw with chute pipe system.

Manual filling

Hopper for manual filling of the pellets

If you want to waive the automatic discharge from a storage room, the integrated pellet hopper of the pelletstar CONDENASTION 10-60 kW can be filled manually (for pelletstar CONDENASTION 80-101 kW is an external hopper necessary or available).

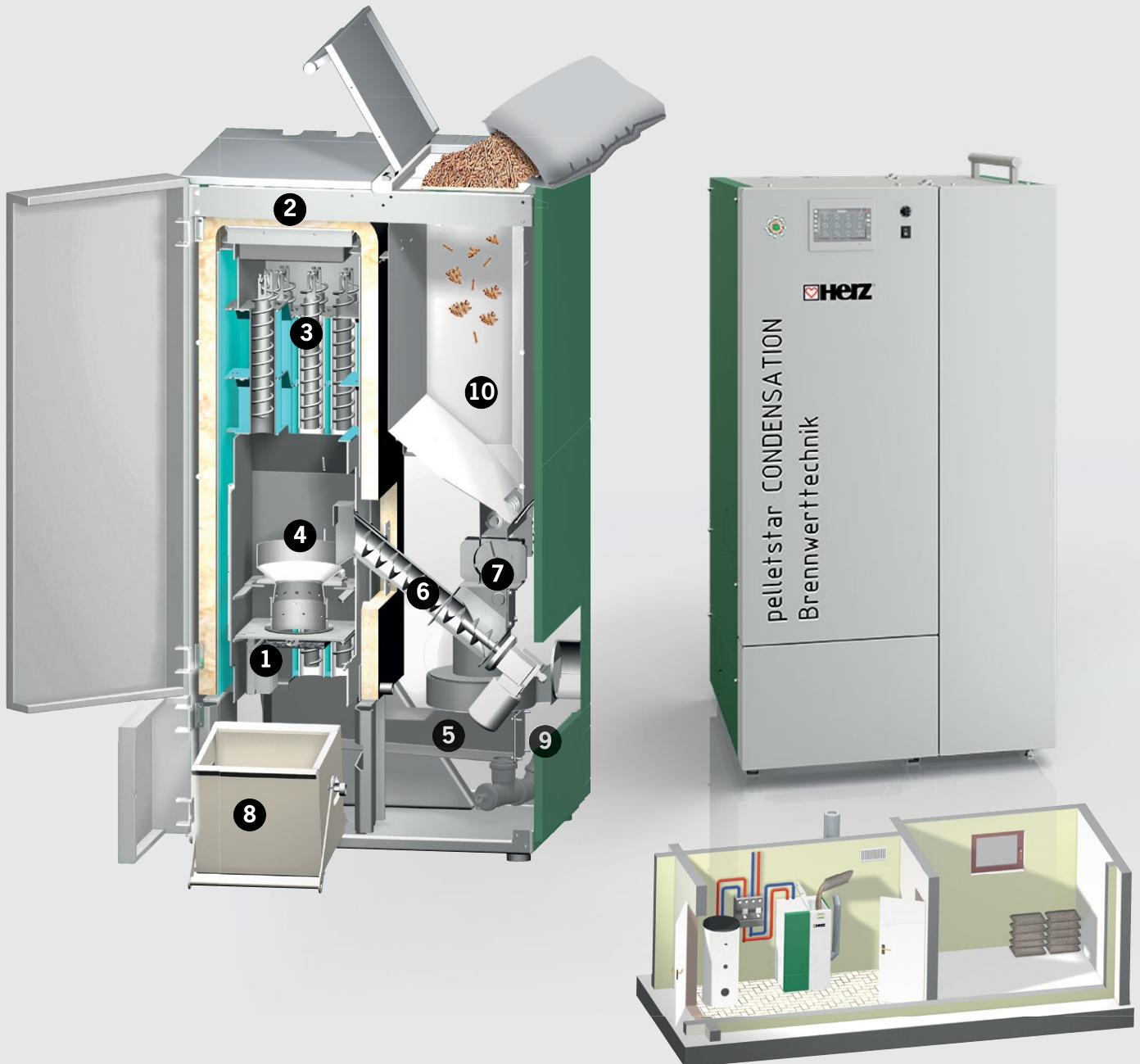

1. **Combustion tipping grate with matrix**
2. **Lambda probe control**
Automatic flue gas and combustion monitoring
3. **Automatic cleaning of the heat exchanger through**
 - integrated turbulators
 - flushing mechanism (water)

4. **Combustion chamber** with tipping grate
5. **ID-fan**
6. **Pellets insertion**
7. **Certified back fire protection flap (BFP):**
 - rotary valve (at integrated hopper or suction hopper)

8. **Ashbox for the combustion ash**
9. **Condensate- and cleaning water drain**
10. **Integrated hand filling hopper**
 - for manual filling:
10-30 kW: 106 litres
45-60 kW: 150 litres

Innovative condensing technology in detail

Generate efficiency rates up to 106%

The HERZ pelletstar CONDENSATION is able to use the so-called "latent" heat contained in the exhaust gas. The usage of this heat takes place while the hot exhaust gas cools down so that the therein existing water vapor condenses and the thereby contained energy (the heat of condensation) is released. This additional heat is added to the heating system.

As a result, efficiencies of up to 106% can be reached and legally required dust emissions can be far undercut!

Increase efficiency and reduce emissions: The heat exchanger surfaces are cleaned automatically via a flushing mechanism (water) as well as via the integrated turbulators. The customers benefit from significant fuel savings and low-emission combustion technology at the highest level.

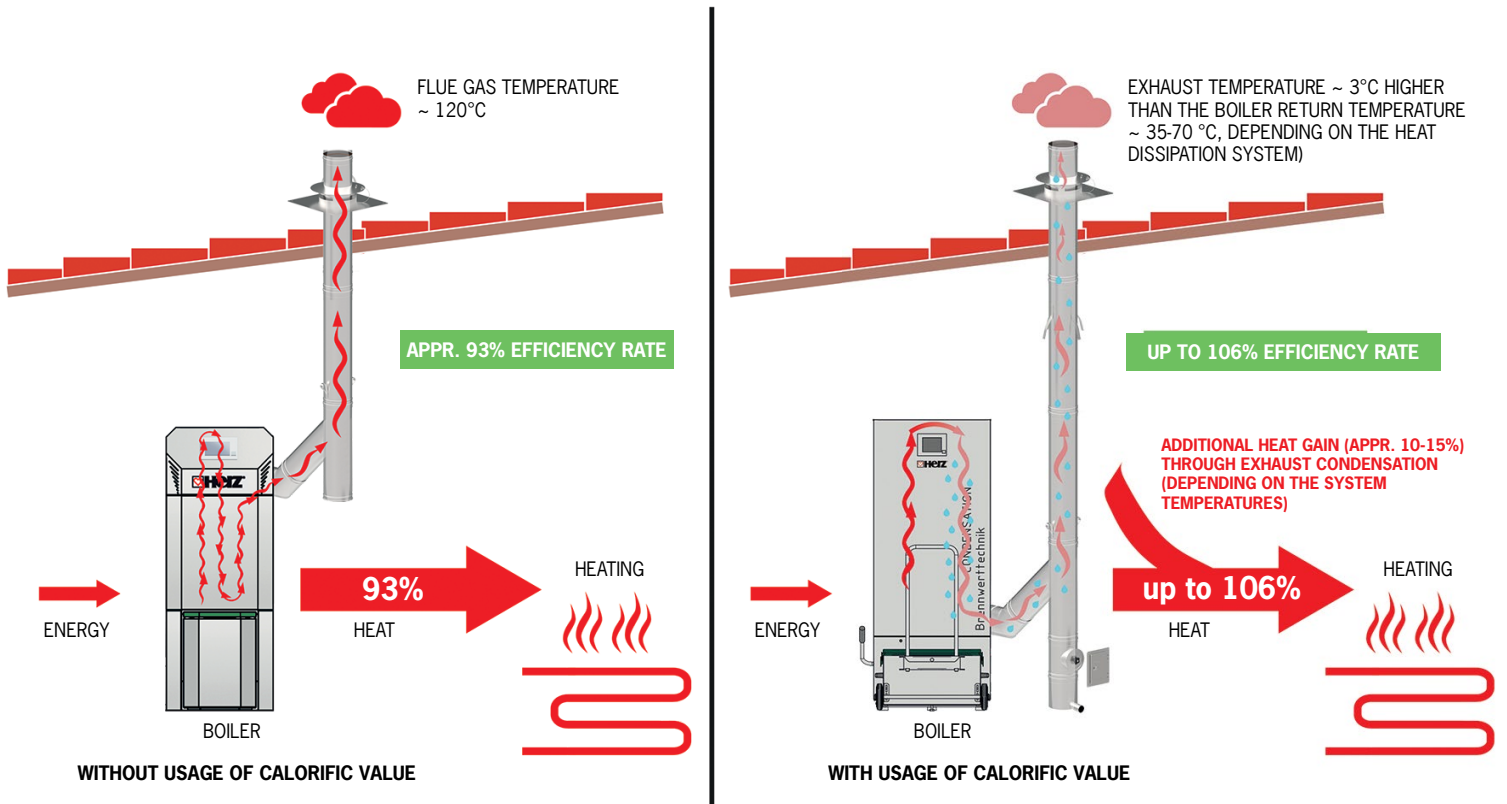
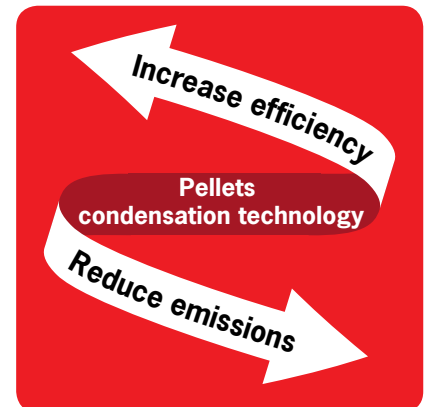

Dimensions & technical data pelletstar CONDENSATION 10-60

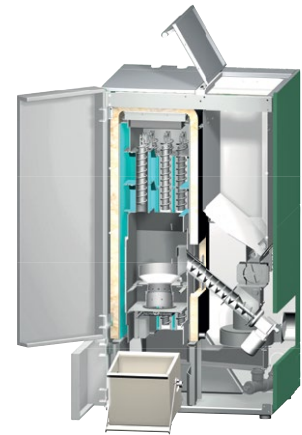
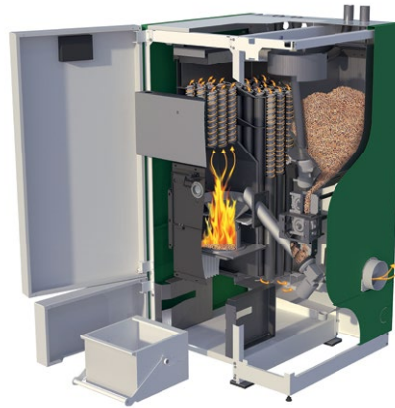
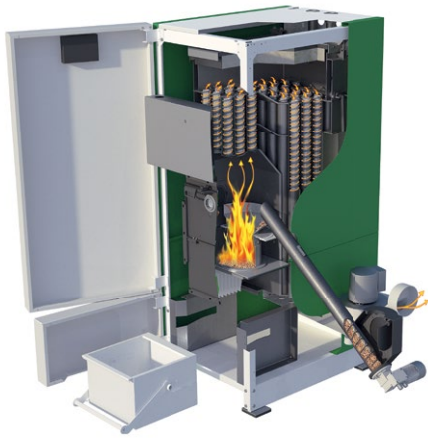

Technical data pelletstar CONDENSATION		10	16	20	30	45	60
Weight: Boiler basic set + Completion set							
Version scew discharge system	kg	340	340	408	408	551	551
Version suction discharge system	kg	403	403	472	472	603	603
Version hand filling system	kg	385	385	470	470	601	601
Volume hand filling hopper	ltr.	106	106	106	106	150	150
Volume suction hopper	ltr.	56	56	56	56	87	87
Efficiency at $\Delta T=20K$ (50°C/30°C) [%]* nominal load condensing operation pellets	%	<106	<106	<106	<106	<106	<106
Efficiency at $\Delta T=20K$ (50°C/30°C) [%] part load condensing operation pellets	%	>103	>103	>103	>103	>103	>103
Efficiency at $\Delta T=20K$ (80°C/60°C) [%] nominal load condensing operation pellets	%	>96	>95	>96	>96	>96	>96
Efficiency at $\Delta T=20K$ (80°C/60°C) [%] part load condensing operation pellets	%	>94	>94	>94	>94	>94	>94
Permissible excess operating overpressure (min./max.)	bar	1,5/3	1,5/3	1,5/3	1,5/3	1,5/3	1,5/3
Max. permissible operating temperature	°C	90	90	90	90	90	90
Min./max. permissible feed pressure (overpressure)	Pa	10/10	10/10	10/10	10/10	8/8	8/8
Water capacity	ltr.	57,5	57,5	77	77	135,0	135,0
Values at nominal load							
Flue gas temperature pellets $\Delta T=20K$ (50°C/30°C)	°C	30,0	32,0	31,5	32,9	30,5	33,0
Flue gas temperature pellets $\Delta T=20K$ (80°C/60°C)	°C	46,8	50,6	51,1	54,0	54,4	56,6
Mass flow flue gas: pellets $\Delta T=20K$ (50°C/30°C)	kg/h	21,6	35,0	39,5	55,2	84,5	115,8
Mass flow flue gas: pellets $\Delta T=20K$ (80°C/60°C)	kg/h	22,7	34,0	40,5	61,0	108,4	131,0
CO ₂ content pellets $\Delta T=20K$ (50°C/30°C)	Vol. %	10,91	11,25	13,88	13,52	13,19	12,98
CO ₂ content pellets $\Delta T=20K$ (80°C/60°C)	Vol. %	23,32	12,6	12,69	13,06	10,83	11,98
Values at part load							
Flue gas temperature pellets $\Delta T=20K$ (50°C/30°C)	°C	28,2	28,3	28,3	28,3	29,4	29,4
Flue gas temperature pellets $\Delta T=20K$ (80°C/60°C)	°C	43,3	43,3	43,0	43,0	44,7	44,7
Mass flow flue gas: pellets $\Delta T=20K$ (50°C/30°C)	kg/h	5,9	8,0	14,6	14,6	35,2	35,2
Mass flow flue gas: pellets $\Delta T=20K$ (80°C/60°C)	kg/h	7,6	7,6	14,8	14,8	34,8	34,9
CO ₂ content pellets $\Delta T=20K$ (50°C/30°C)	Vol. %	10,40	10,43	10,60	10,60	10,05	10,05
CO ₂ content pellets $\Delta T=20K$ (80°C/60°C)	Vol. %	10,93	10,93	10,25	10,25	10,04	10,04
Energy efficiency class							
Biomass boiler		A++	A++	A++	A++	A++	A++
Biomass boiler with integrated system controller		A++	A++	A++	A++	A++	A++

The right to make technical amendments is reserved.

Dimensions & technical data pelletstar CONDENSATION 10-60

Discharge set suction system

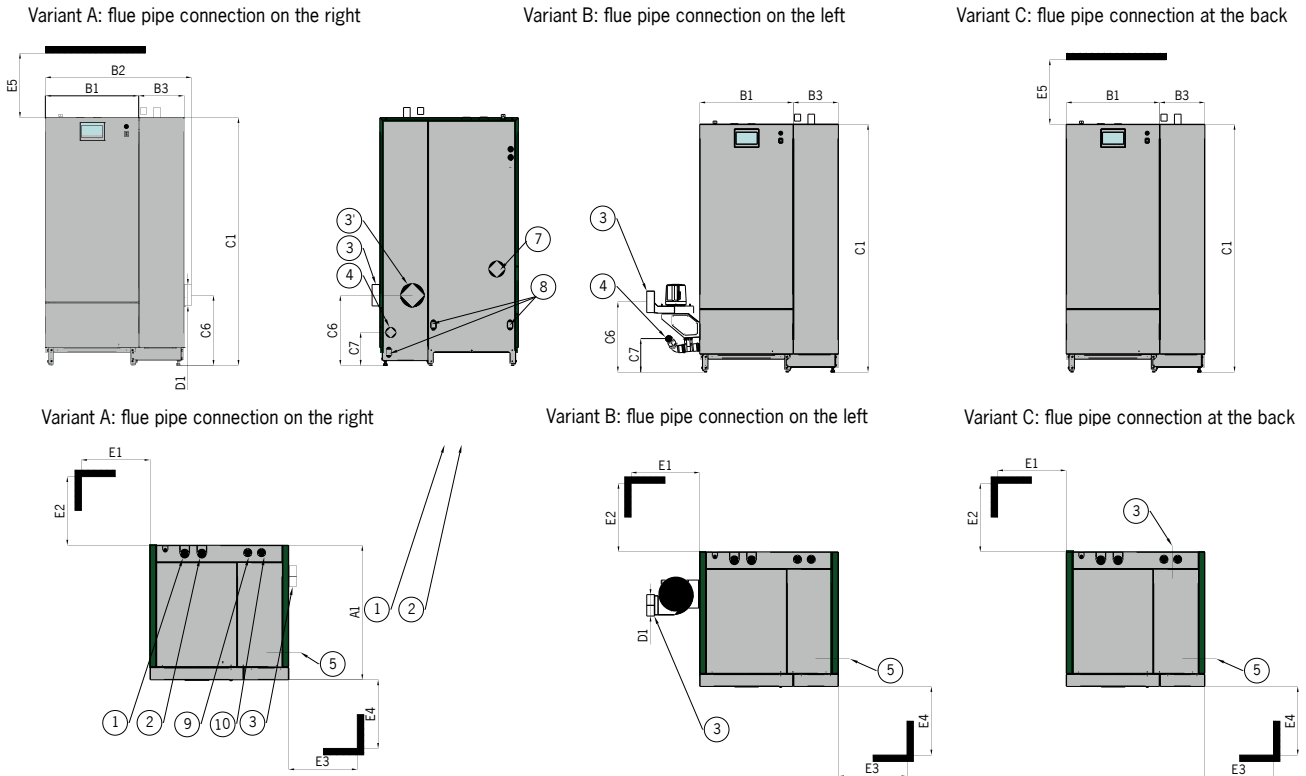

Discharge set hand filling system

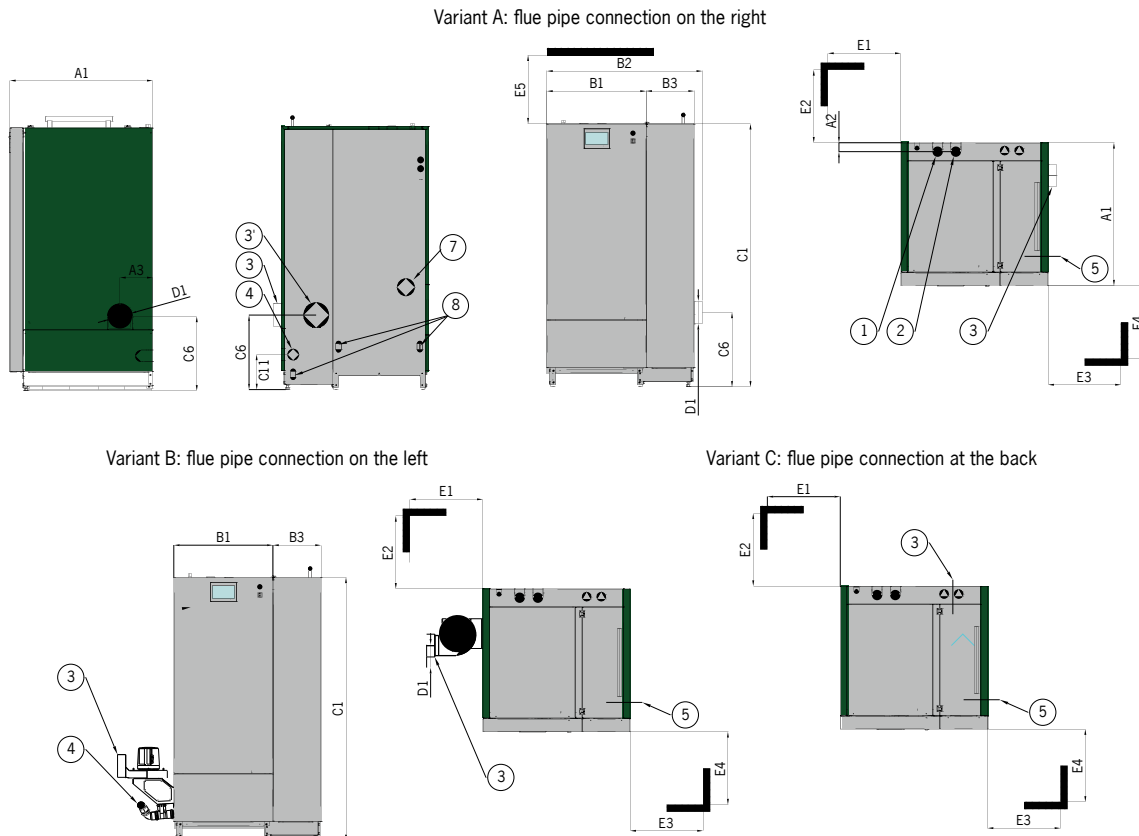

The right to make technical amendments is reserved.

Dimensions & technical data pelletstar CONDENSATION 10-60

Discharge set screw discharge system

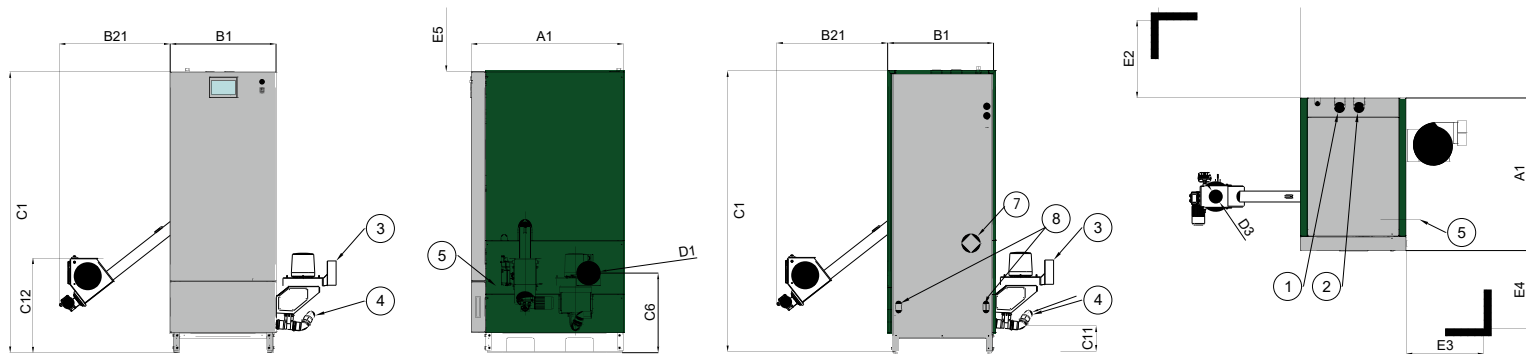

Variant A:
Flue pipe connection on the right
Pellet insertion on the left

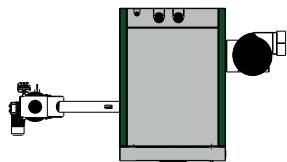

Variant B:
Flue pipe connection on the left
Pellet insertion on the right

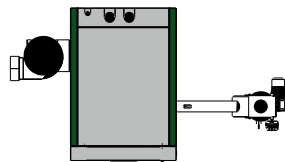

Variant C:
Flue pipe connection on the left
Pellet insertion on the left

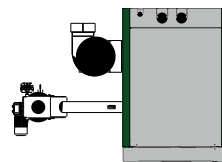

Variant D:
Flue pipe connection on the right
Pellet insertion on the right

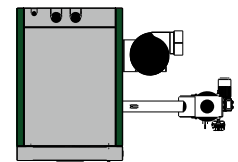

Technical data pelletstar CONDENSATION

		10	16	20	30	45	60
Output range	kW	3,2-10,0	3,2-16,0	6,0-20,0	6,0-30,0	13,0-45,0	13,0-60,0

Dimensions

A1	Length - total	mm	730	730	730	730	980	980
B1	Width basic boiler	mm	530	530	680	680	680	680
B2	Width total suction discharge system	mm	913	913	1063	1063	1066	1066
B2	Width total manual filling system	mm	913	913	1063	1063	1066	1066
B3	Width suction hopper	mm	330	330	330	330	330	330
B3	Width hand filling hopper	mm	330	330	330	300	330	330
B21	Width screw discharge system	mm	557	557	482	482	713	713
C1	Height	mm	1580	1580	1580	1580	1805	1805
C6	Height flue pipe - centre	mm	364	364	364	364	511	511
C7	Height: middle of the condensate drain	mm	156	156	156	156	156	156
C12	Height BFP	mm	547	547	547	547	547	547
D1	Diameter flue pipe outlet	mm	132	132	132	132	152	152
D3	Diameter flange BFP	mm	90	90	-	-	90	90
E1	Minimal gap (A/B/C/D) screw discharge	mm	750/500/750/50		675/500/675/50		910/500/910/50	
E2	Minimal gap (A/B/C/D - A'/B'/C'/D') screw discharge	mm	50/50/-/50 500'/500'/500'/500'		50/50/-/50 500'/500'/500'/500'		50/50/50/50 500'/500'/500'/500'	
E3	Minimal gap (A/B/C/D) screw discharge	mm	500/750/50/750		500/675/50/675		500/910/50/910	
E1	Minimal gap (A/B/C) Hand filling/suction discharge	mm	50/500/50		50/500/50		50/500/50	
E2	Minimal gap (A/B/C - B') Hand filling/suction discharge	mm	50/50/500 - 500'		50/50/500 - 500'		50/50/500 - 500'	
E3	Minimal gap (A/B/C) Hand filling/suction discharge	mm	500/50/50		500/50/50		500/50/50	
E4	Minimal gap	mm	750	750		750		750
E5	Minimal gap	mm	470	470		470		470
	Inserting dimensions - depth	mm	730 (A1)	730 (A1)		730 (A1)		980 (A1)
	Inserting dimensions - width	mm	530 (B1)	530 (B1)		680 (B1)		680 (B1)
	Inserting dimensions - height	mm	1580 (C1)	1580 (C1)		1580 (C1)		1805 (C1)
1	Flow		1" IT	1" IT	1" IT	1" IT	6/4" IT	6/4" IT
2	Back flow		1" IT	1" IT	1" IT	1" IT	6/4" IT	6/4" IT
3	Flue pipe connection		132 mm	132 mm	132 mm	132 mm	152 mm	152 mm
4	Condensation drain		DN50	DN50	DN50	DN50	DN50	DN50
5	Filling/emptying (under the casing)		1/2" ET	1/2" ET	1/2" ET	1/2" ET	1/2" ET	1/2" ET
7	Connection option: combustion with outside air intake (option)		Øa 75mm	Øa 75mm	Øa 75mm	Øa 75mm	Øa 75mm	Øa 75mm
8	Cold water connection		3/4" IT	3/4" IT	3/4" IT	3/4" IT	3/4" IT	3/4" IT
9	Suctiontube connection		Øa 45mm	Øa 45mm	Øa 45mm	Øa 45mm	Øa 45mm	Øa 45mm
10	Reverse air tube connection		Øa 48,3mm	Øa 48,3mm	Øa 48,3mm	Øa 48,3mm	Øa 48,3mm	Øa 48,3mm
IT	Internal thread							

The right to make technical amendments is reserved.

' Versions with flue pipe on the back side

Dimensions & technical data pelletstar CONDENSATION 80-101

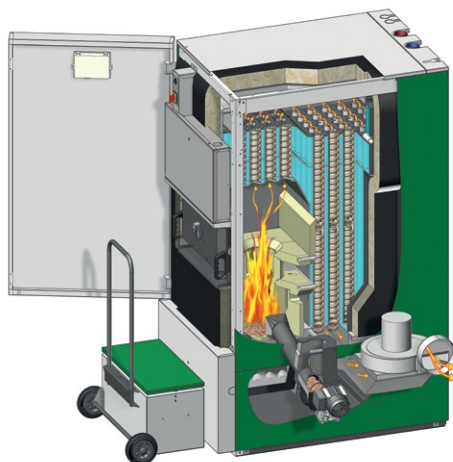

Technical data pelletstar CONDENSATION		80	100	101
Boiler weight	kg	841	841	841
Efficiency at $\Delta T=20K$ (50°C/30°C) [%] nominal load condensing operation pellets	%	>103	>102	>102
Efficiency at $\Delta T=20K$ (50°C/30°C) [%] part load condensing operation pellets	%	>104	>104	>104
Efficiency at $\Delta T=20K$ (80°C/60°C) [%] nominal load condensing operation pellets	%	>97	>96	>96
Efficiency at $\Delta T=20K$ (80°C/60°C) [%] part load condensing operation pellets	%	>96	>96	>96
Min./max. permissible feed pressure (overpressure)	Pa	5/8	5/8	5/8
Permissible excess operating overpressure (min./max.)	bar	1,5/3	1,5/3	1,5/3
Max. permissible operating temperature	°C	95	95	95
Water capacity	ltr.	195	195	195
Values at nominal load				
Flue gas temperature pellets $\Delta T=20K$ (50°C/30°C)	°C	34	35	35
Flue gas temperature pellets $\Delta T=20K$ (80°C/60°C)	°C	61	63	63
Mass flow flue gas: pellets $\Delta T=20K$ (50°C/30°C)	kg/h	172	211	213
Mass flow flue gas: pellets $\Delta T=20K$ (80°C/60°C)	kg/h	192	224	226
CO ₂ content pellets $\Delta T=20K$ (50°C/30°C)	Vol. %	12,1	11,9	11,9
CO ₂ content pellets $\Delta T=20K$ (80°C/60°C)	Vol. %	11,5	11,9	11,9
Values at part load				
Flue gas temperature pellets $\Delta T=20K$ (50°C/30°C)	°C	30	30	30
Flue gas temperature pellets $\Delta T=20K$ (80°C/60°C)	°C	52	52	52
Mass flow flue gas: pellets $\Delta T=20K$ (50°C/30°C)	kg/h	55	55	55
Mass flow flue gas: pellets $\Delta T=20K$ (80°C/60°C)	kg/h	61	61	61
CO ₂ content pellets $\Delta T=20K$ (50°C/30°C)	Vol. %	10,9	10,9	10,9
CO ₂ content pellets $\Delta T=20K$ (80°C/60°C)	Vol. %	11,0	11,0	11,0

The right to make technical amendments is reserved.

Dimensions & technical data pelletstar CONDENSATION 80-101

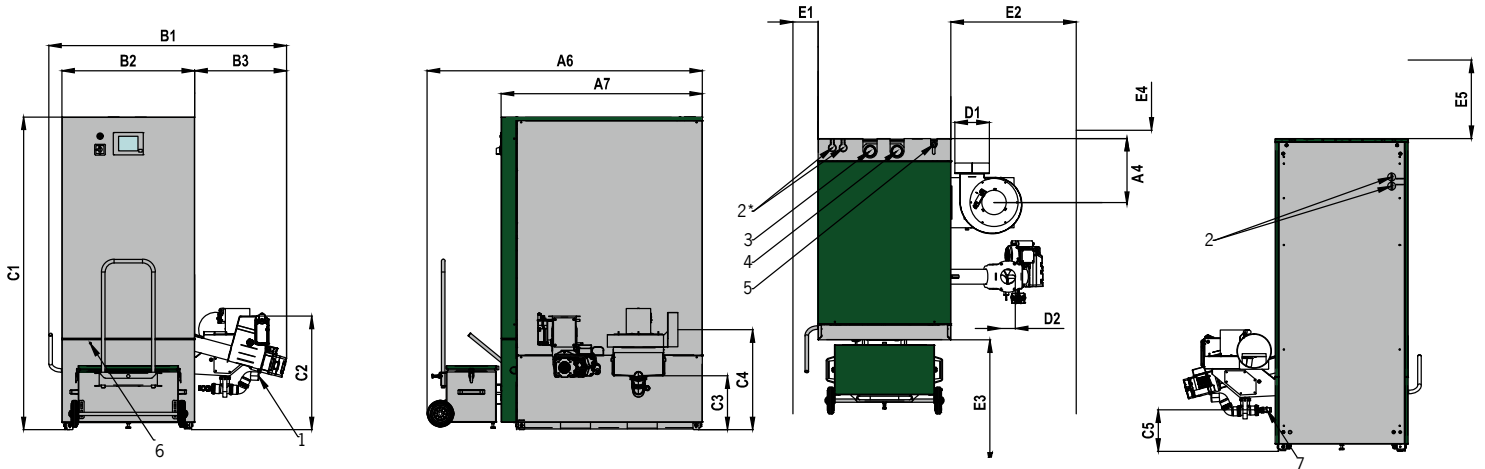

Illustration: pellet insertion on the right side - optionally also available on the left side

Technical data pelletstar CONDENSATION			80	100	101
Output range		kW	24 - 80	24 - 99	24 - 101
Dimensions					
A6	Length - total	mm	1645	1645	1645
A7	Length - casing	mm	1205	1205	1205
B1	Width - total	mm	1425	1425	1425
B2	Width - casing	mm	795	795	795
B3	Width	mm	550	550	550
C1	Height	mm	1870	1870	1870
C3	Height: middle of the condensate drain	mm	325	325	325
C4	Height: middle of the ID	mm	600	600	600
C5	Height: cold water connection	mm	250	250	250
D1	Diameter flue pipe outlet	mm	Øi 182	Øi 182	Øi 182
D2	Diameter flange BFP	mm	90	90	90
E1	Minimum space left	mm	150	150	150
E2	Minimal gap	mm	750	750	750
E3	Minimal gap	mm	750	750	750
E4	Minimal gap	mm	50	50	50
E5	Minimal gap	mm	470	470	470
	Inserting dimensions - depth	mm	1200	1200	1200
	Inserting dimensions - width	mm	800	800	800
	Inserting dimensions - height	mm	1900	1900	1900
1	Condensation drain		DN 50	DN 50	DN 50
2	Cable bushing		-	-	-
2*	Cable ducts (optional)		-	-	-
3	Flow		2" IG	2" IG	2" IG
4	Back flow		2" IG	2" IG	2" IG
5	Safety heat exchanger connection		1/2" IT	1/2" IT	1/2" IT
6	Filling/emptying (under the casing)		1/2" ET	1/2" ET	1/2" ET
7	Cold water connection		3/4" IG	3/4" IG	3/4" IG
	IT		internal thread		
	ET		external thread		

The right to make technical amendments is reserved.

The specified free area must be strictly adhered to when carrying out maintenance and service work.

Possibilities and combinations with external hand filling and suction hoppers

Hopper for the discharge with a suction system

The suction hopper FLEX (with integrated suction turbine) is available in 3 different sizes:

Dimensions hopper (mm)		Dimensions of the boiler with hopper (mm)			
Hopper type		pelletstar CONDENSATION			
		80	100	101	
Suction hopper FLEX 140 litres / 91 kg		✓	✓	✓	
A1 Length	442 mm	P1 / P2 / P3 Length	2348 / 1640 / 2378	2348 / 1640 / 2378	2348 / 1640 / 2378
B1 Width	440 mm	Q1 / Q2 / Q3 Width	1897 / 3136 / 1904	1897 / 3136 / 1904	1897 / 3136 / 1904
C1 Height	1660 / +25 mm*	It is essential to observe compliance with the minimum room heights!			
Suction hopper FLEX 350 litres / 225 kg		✓	✓	✓	
A1 Length	602 mm	P1 / P2 / P3 Length	2428 / 1640 / 2758	2428 / 1640 / 2758	2428 / 1640 / 2758
B1 Width	1200 mm	Q1 / Q2 / Q3 Width	1897 / 3216 / 1984	1897 / 3216 / 1984	1897 / 3216 / 1984
C1 Height	1714 / +10 mm*	It is essential to observe compliance with the minimum room heights!			
Double suction hopper FLEX 350 litres / 225 kg		✓	✓	✓	
A1 Length	602 mm	P1 / P2 / P3 Length	2428 / 1640 / 2758	2428 / 1640 / 2758	2428 / 1640 / 2758
B1 Width	1200 mm	Q1 / Q2 / Q3 Width	1897 / 3216 / 1984	1897 / 3216 / 1984	1897 / 3216 / 1984
C1 Height	1714 / +10 mm*	It is essential to observe compliance with the minimum room heights!			

* Adjustable screw feet

The suction hopper can be placed variably, depending on the local conditions, in front of, next to or behind the boiler. The examples of the hopper placement options shown below, represent the "ID right" variant. With the variant "ID left", it is not possible to place the hopper behind the boiler - therefore Q1 and P1 are not relevant.

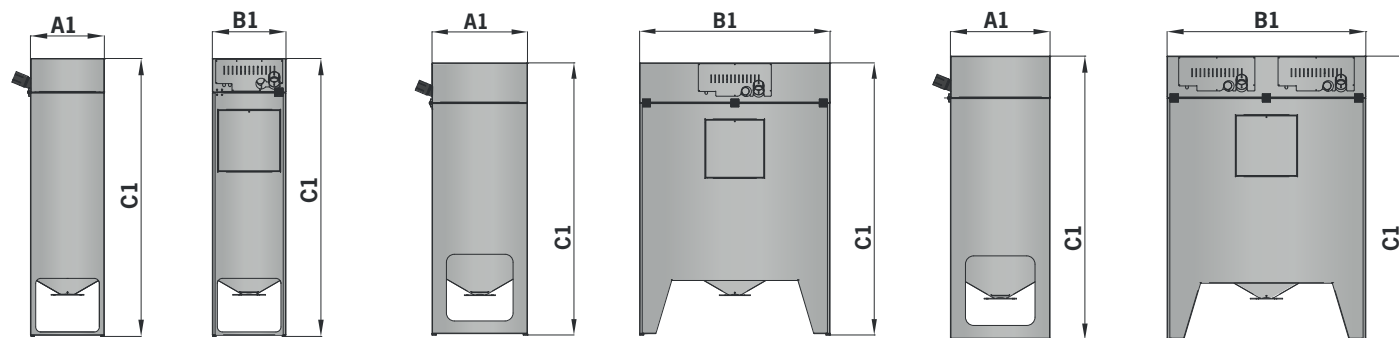
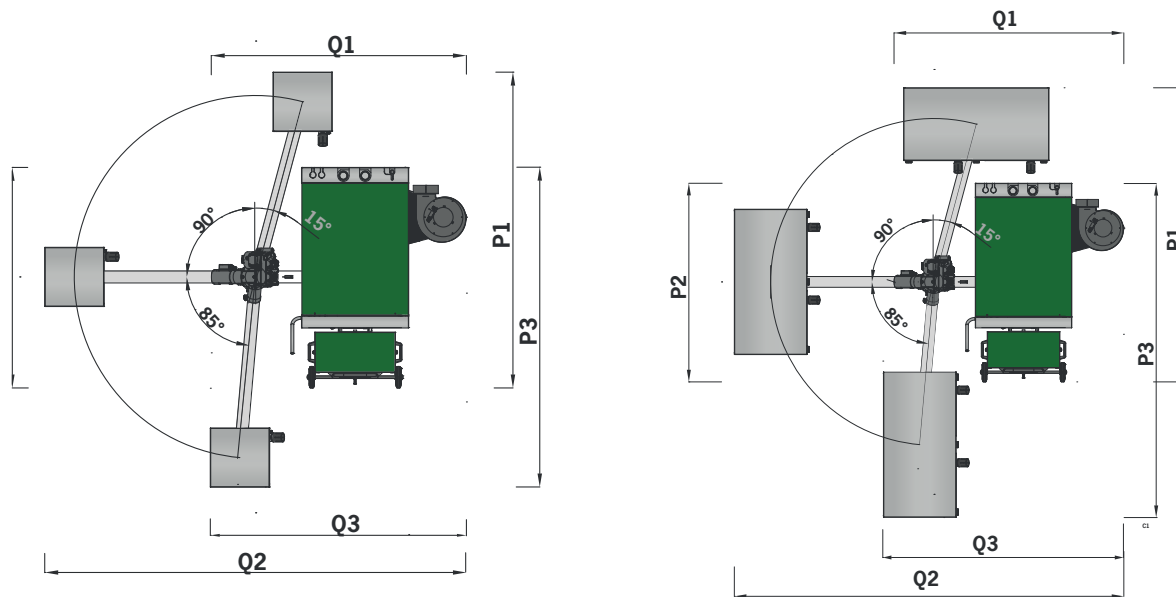

Suction hopper FLEX 140

Suction hopper FLEX 350

Double suction hopper FLEX 385

Hopper for hand filling

If the automatic discharge from a storage room is not required, the customer has the option for filling the hopper manually by hand. The manual filling hopper is available in 3 sizes:

Dimensions hopper (mm)		Dimensions of the boiler with hopper (mm)		
Hopper type		pelletstar CONDENSATION		
		80	100	101
Manual filling hopper FLEX 225 litres / 143 kg		✓	✓	✓
A1 Length	442 mm	P1 / P2 / P3 Length	2367 / 1640 / 2378	2367 / 1640 / 2378
B1 Width	440 mm	Q1 / Q2 / Q3 Width	1897 / 3155 / 1923	1897 / 3155 / 1923
C1 Height	1504 / +25 mm*	It is essential to observe compliance with the minimum room heights!		
Manual filling hopper FLEX 400 litres / 260 kg		✓	✓	✓
A1 Length	602 mm	P1 / P2 / P3 Length	2430 / 1640 / 2458	2430 / 1640 / 2458
B1 Width	600 mm	Q1 / Q2 / Q3 Width	1897 / 3217 / 1986	1897 / 3217 / 1986
C1 Height	1495 / +10 mm*	It is essential to observe compliance with the minimum room heights!		
Manual filling hopper FLEX 740 litres / 480 kg		✓	✓	✓
A1 Length	602 mm	P1 / P2 / P3 Length	2348 / 1640 / 2378	2348 / 1640 / 2758
B1 Width	1200 mm	Q1 / Q2 / Q3 Width	1897 / 3136 / 1904	1897 / 3136 / 1904
C1 Height	1495 / +10 mm*	It is essential to observe compliance with the minimum room heights!		

* Adjustable screw feet

The suction hopper can be placed variably, depending on the local conditions, in front of, next to or behind the boiler. The examples of the hopper placement options shown below, represent the "ID right" variant.

With the variant "ID left", it is not possible to place the hopper behind the boiler - therefore Q1 and P1 are not relevant.

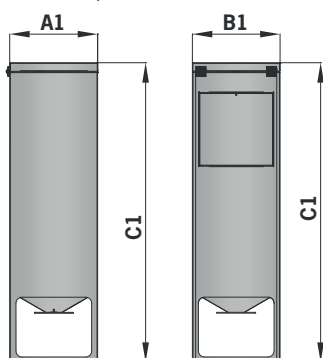
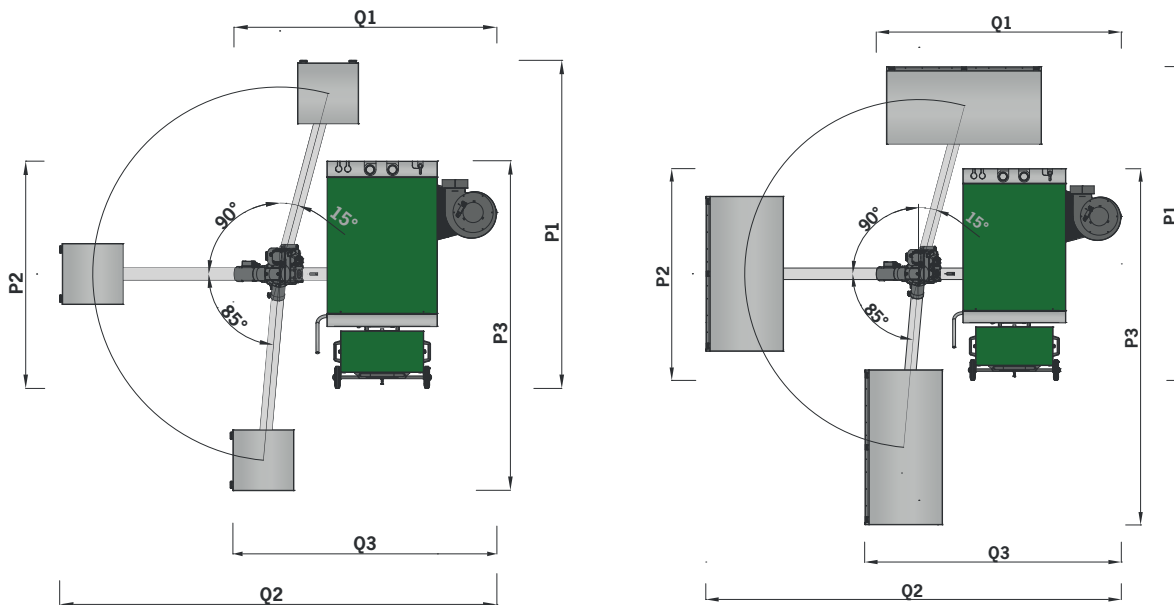

Hand filling hopper FLEX 225

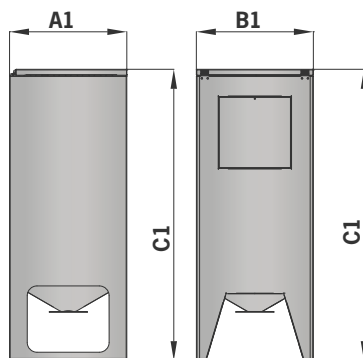

Hand filling hopper FLEX 400

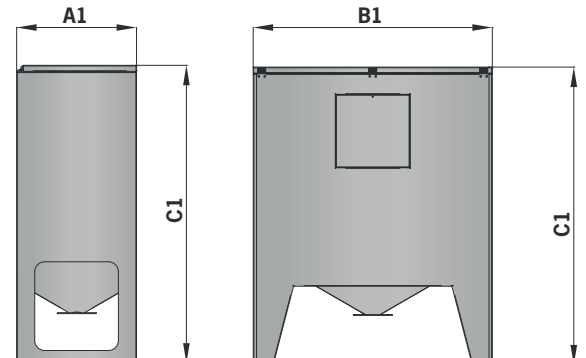

Hand filling hopper FLEX 740

HERZ customer-oriented...

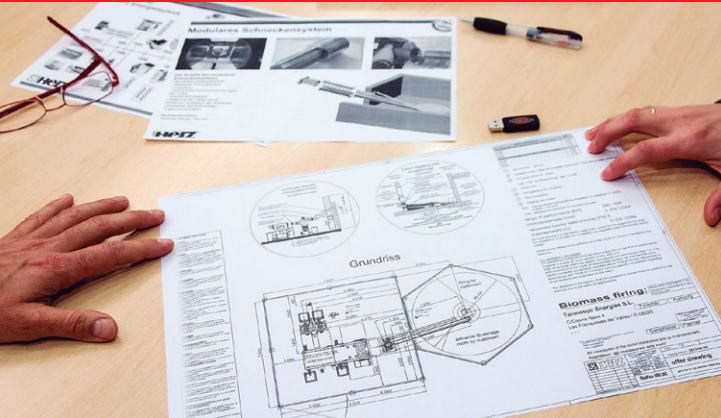

- Advising in planning phase
- Planning of discharge system according to customer requirements and local conditions
- Area covered service

- HERZ training:
 - for operators
 - for planners, technical departments
 - for plumbers
 - as well as continuous training of the maintenance staff

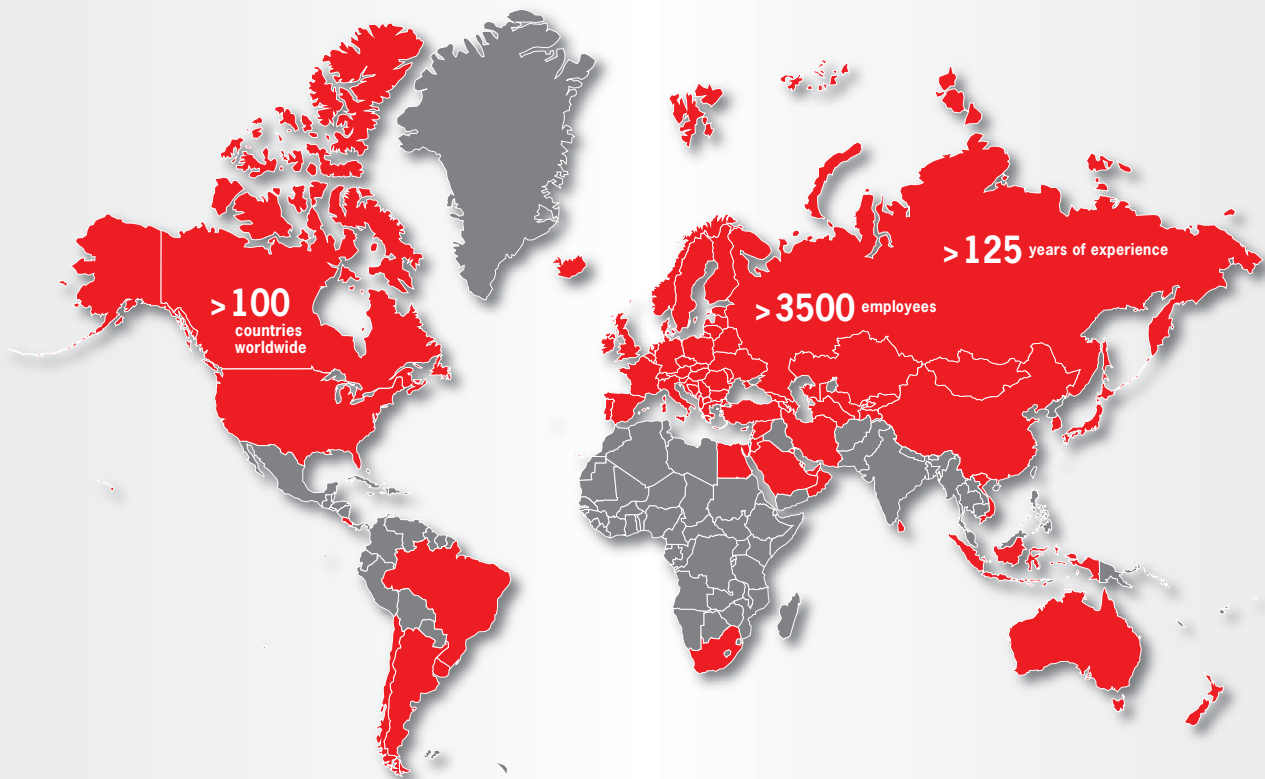

HERZ Energietechnik GmbH

Herzstraße 1, 7423 Pinkafeld
Austria

Tel.: +43 (0) 3357 / 42840-0

Fax: +43 (0) 3357 / 42840-190

Mail: office-energie@herz.eu

Web: www.herz-energie.at

HERZ Armaturen GmbH

Fabrikstraße 76, 71522 Backnang
Germany

Tel.: +49 (0) 7191 / 9021-0

Fax: +49 (0) 7191 / 9021-79

Mail: zentrale-bk@herz.eu

Web: www.herz-energie.at

Your partner:

