

HERZ STRÖMAX GNW for drinking water systems

STRÖMAX-GNW commissioning valve with test points

Data sheet for STRÖMAX 4217 GNW, Issue 1023

Dimensions in mm

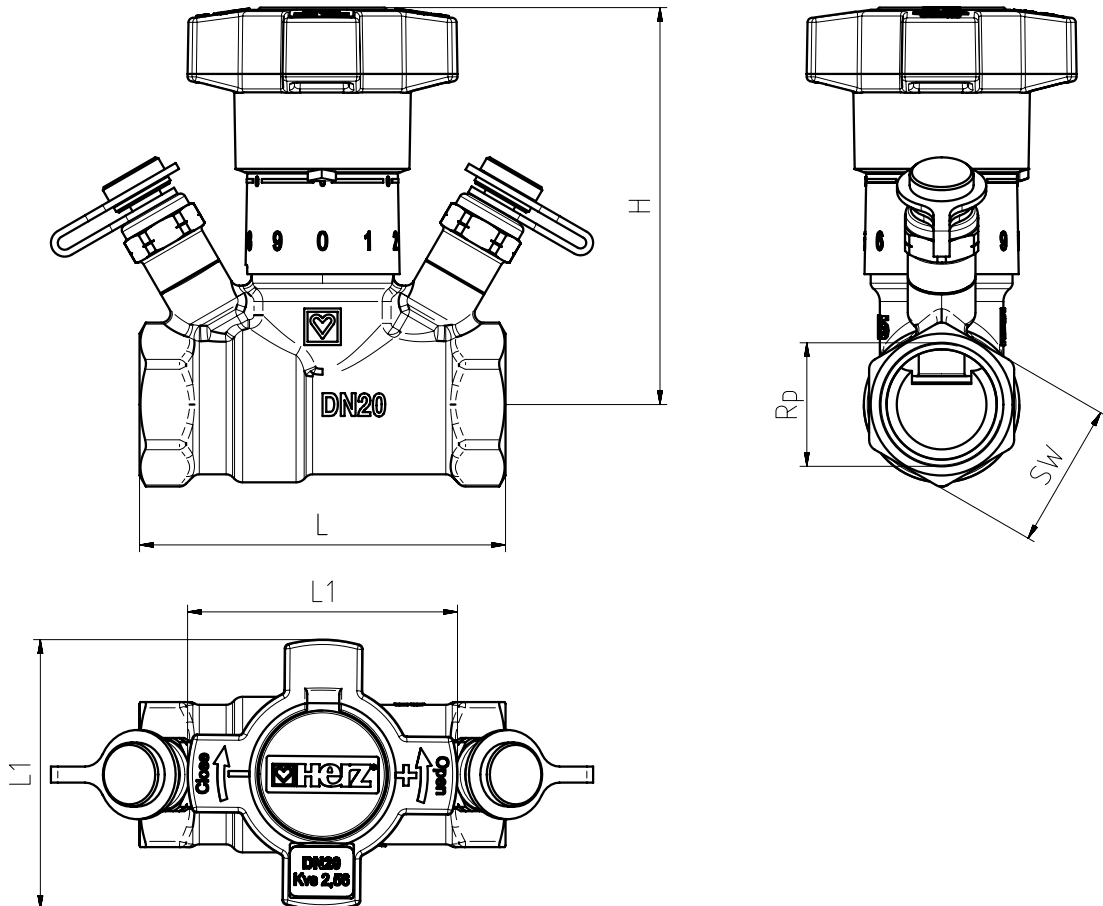

Order number	DN	Rp	L	L1	H (close/open)	SW Hexagon	SW Octagon	Weight, kg	kvs
4217 GNW									
2 4217 71	15	1/2"	78	59	84/92	27		0,50	1,76
2 4217 72	20	3/4"	80	59	87/95	32		0,58	2,38
2 4217 73	25	1"	88	59	94/102	41		0,81	5,24
2 4217 74	32	1 1/4"	106	59	102/114		50	1,20	8,56
2 4217 75	40	1 1/2"	116	59	102/114		55	1,37	11,53
2 4217 76	50	2"	132	59	107/119		70	2,06	17,16

☑ Models

STRÖMAX-GNW commissioning valve with equal percentage characteristic graph and test points, 1/2" – 2". Screw down model, brass version, socket x socket, rising spindle, spindle seal by means of double-O-ring, presetting by limitation of valve lift by means of internal spindle; display of presetting step on the handwheel shaft.

☑ Test points

2 test points are located adjacent to the hand wheel at identical angles, sealed by the manufacturer. This arrangement permits optimum access and connection of measuring instruments in any position of installation.

☑ Certification



2 **4217 7X** are certified by WIEN-ZERT with the Austrian ÜA-sign for potable water.

☑ Field of Application

To use in potable water applications. For non-aggressive fluids in home, trade and industry. Use only ammoniac free sealing materials. Don't use sealing additives with mineral oil components. Close the valve clockwise.

☑ Technical data

Allowed operating data according to ÖVGW-Certification:

Max. operating pressure	10 bar (PN10)
Max. operating temperature	65 °C

Technically possible operation data:

Max. operating temperature	85 °C
Max. operating pressure	25 bar

HERZ plastic pipe connections max. operating temperature 95 °C and max. operating pressure 10 bar, if approved by the pipe manufacturer.

Ammonia contained in hemp can damage brass valve bodies, EPDM gaskets can be affected by Mineral oils lubricants and thus lead to failure of the EPDM seals.

☑ Material and construction

Body and spindle	brass acc. to UBA-list and 4MS-list
Hand wheel	Polyamide, green
Spindle seals	double O-ring made of EPDM
Internal threaded connectors	acc. ISO 7/1

☑ Flow Direction

During installation, take into account the flow direction arrow on the valve body.

☑ Installation Position

The valve spindle arranged perpendicular to the valve axis guarantees optimum accessibility and optimum valve operation in any installation position.

☑ Presetting

The current position of the flow restriction cone is shown on a clearly visible scale of the body. The STRÖMAX-GNW commissioning valves are supplied in open position, preset to permit the maximum possible valve lift. The hand wheel mechanism is adjusted in such a way that the handwheel display will be 0, when the valve is closed.

Presetting Procedure:

1. Open the valve to the desired value according to calculation.
2. Lift the ring with the scale.
3. Turn clockwise the ring with the scale to the stop.
4. Lift the scale part up and set „0“ to the front.
5. Lower the ring with scale to the „click“.
6. Mark the step set at the presetting marker and attach the marker to the valve.

Point 6 is not necessary for function, but is recommended.

☑ Presetting Marker

The pre-setting marker (1 6517 05) is fastened as a tag above the valve or pipe. The setting of the respective valve is marked by cutting or breaking off the teeth at the figures for full and partial turns.



This permits checking and/or restoration of the original pre-setting made on the occasion of the system set-up after servicing without having to rely on documentation.

☑ Differential Pressure Measurement

The STRÖMAX-GNW commissioning valve is equipped with two test points. The differential pressure can be measured using a suitable measuring instrument, which permits calculation of the flow rate as a function of the respective presetting step. The HERZ-Measuring computer (1 8900 05) permits direct flow rate reading (consult the equipment manual).

☑ Accessories and Spare Parts

1 6517 05	Pre-setting marker
1 8900 05	HERZ measuring computer
2 0284 05	Test points, brass version, blue cap (return), 1/8"
2 0284 06	Test points, brass version, red cap (supply), 1/8"

☑ Measuring

To achieve a precise measurement, you need a straight pipe before and afterwards.

According to CIBSE Code W double regulating valves must always be installed with a minimum of 5 pipe diameters of straight pipe, without intrusion, upstream of the valve. Downstream of the valve a minimum of 2 pipe diameters of straight pipe are required. If a pump is installed directly before the valve, we recommend 10 pipe diameters of straight pipe, without intrusion, upstream of the valve.

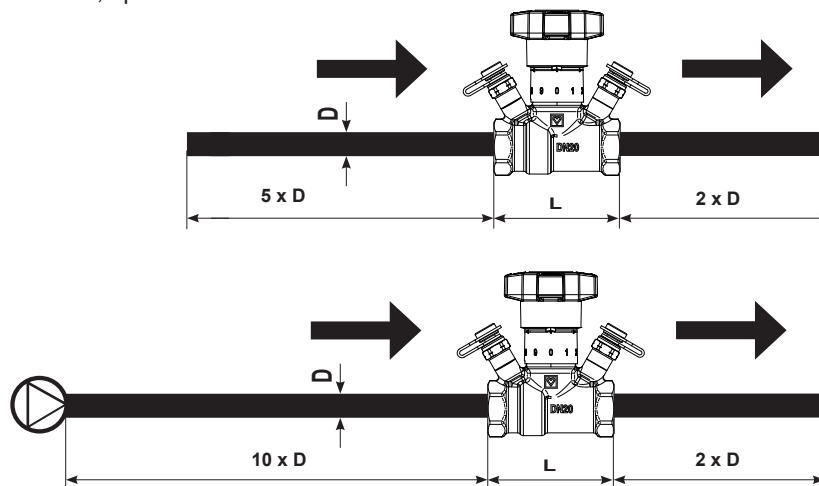

☑ Brass

HERZ uses top-quality brass that is in compliance with DIN EN 12164, DIN EN 12165, DIN EN 1982, the UBA and 4MS lists.

Pursuant to Article 33 of the REACH Regulation (EC No. 1907/2006), we are obliged to point out that the material lead is listed on the SVHC list and that all brass components manufactured in our products exceed 0.1% (w / w) lead (CAS: 7439-92-1 / EINECS: 231-100-4). Since lead is a component part of an alloy, actual exposure is not possible and therefore no additional information on safe use is necessary.

☑ Disposal instruction

The disposal of HERZ STRÖMAX commissioning valves must not endanger the health or the environment. National legal regulations for proper disposal of the HERZ STRÖMAX commissioning valves have to be followed.

Please note: all diagrams are indicative in nature and do not claim to be complete.

All specifications and statements within this document are according to information available at the time of printing and meant for informational purpose only. Herz Armaturen reserves the right to modify and change products as well as its technical specifications and/or its functioning according to technological progress and requirements. It is understood that all images of Herz products are symbolic representations and therefore may visually differ from the actual product. Colours may differ due to printing technology used. In case of any further questions don't hesitate to contact your closest HERZ Branch-office.

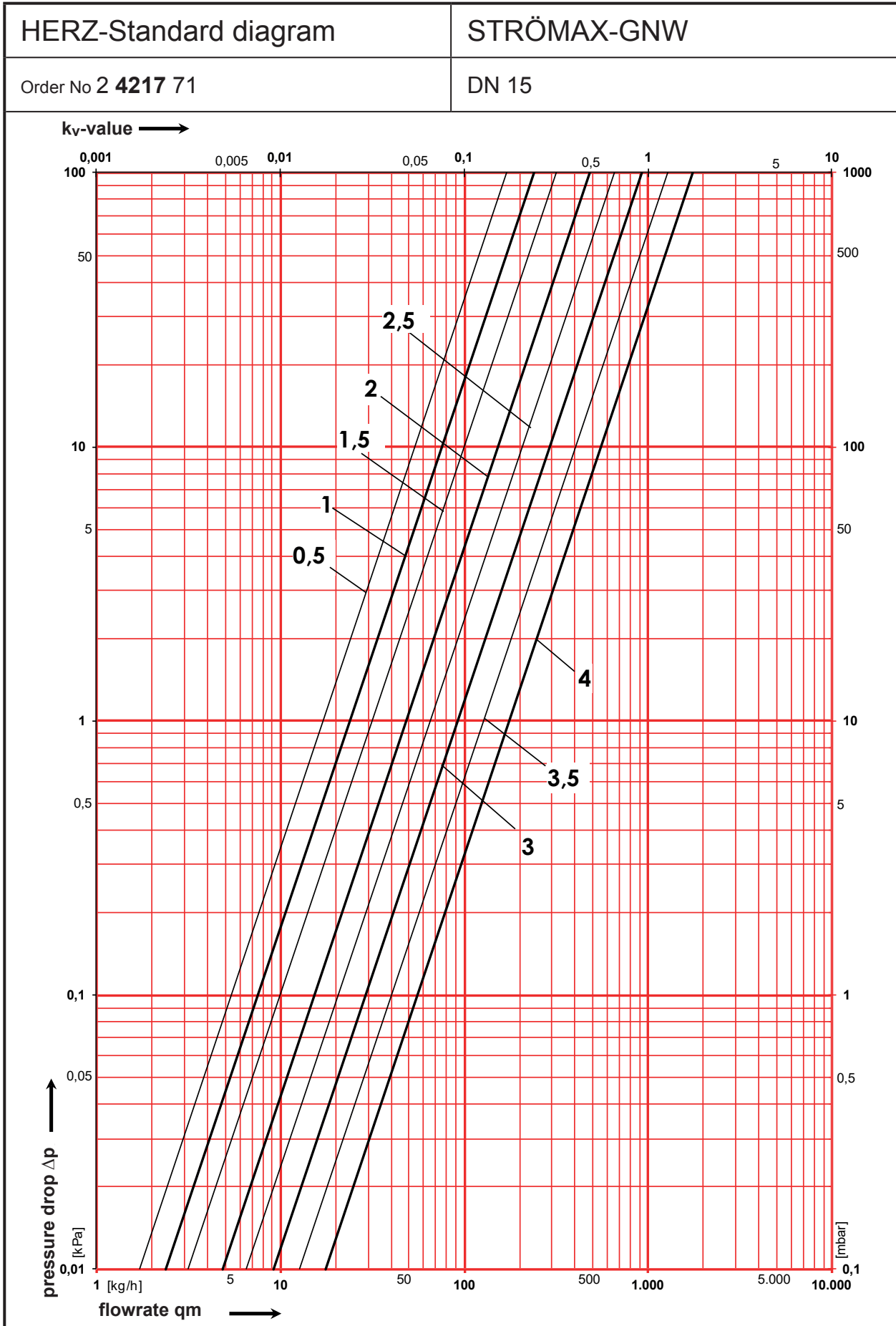

HERZ-Standard diagram	STRÖMAX-GNW
Order No 2 4217 72	DN 20

